

Dear Customer,

Thank you for choosing a Moto Guzzi vehicle.

We have prepared this booklet for you to appreciate the qualities of the vehicle. We recommend that you read it in its entirety before you start riding for the first time, familiarize yourself with the controls and understand the behaviour of the vehicle in order to use it correctly. This document contains tips, warnings and important information for the safety, correct operation, maintenance and care of your vehicle. We advise you to keep this booklet for easy consultation and to hand it over to the new owner in the event of sale, as it constitutes an integral part of the vehicle itself. We hope you enjoy reading this manual. Have a great journey!

We strongly recommend that you download and view the full and updated version of the present document, which is available from the website:

<https://manuals.motoguzzi.com>

# V100 Mandello - V100 Mandello S



Ed: 02-05\_2025 Cod. 2Q000594 (USA)

## INSTRUCTIONS

The instructions given in this manual are intended to provide a clear and simple guide for using your vehicle. Details are also given of routine maintenance procedures and regular checks which should be carried out on the vehicle by a Moto Guzzi dealer or authorised service centre.

Any operations not specifically described in this booklet require the use of special tools and/or particular technical knowledge: we recommend having these operations carried out by a Moto Guzzi dealer or authorised service centre.

Read this manual thoroughly before using your vehicle. Follow the instructions contained in this manual for your personal safety and to ensure the durability of your vehicle. Failure to observe these instructions may cause personal injury or damage to the vehicle.

## WARNING

This use and maintenance manual contains descriptions of the technical data and functional characteristics of the vehicle applicable for the different variants and configurations currently in production. Only the information relative to the configuration, engine variant and version of the vehicle purchased by you must be taken into consideration.

Piaggio & C. S.p.A. reserves the right to implement modifications to the model described in this document at any time, for any technical or commercial reasons it deems fit.

## CHANGE/MODIFY THE VEHICLE

Any modifications or alterations made to the vehicle may void the warranty and may also compromise the road-holding characteristics of the vehicle and cause an accident, putting the safety of the driver and occupants at serious risk.

This use and maintenance manual contains paragraphs identified by signal word DANGER, with warnings for avoiding accident or injury, and paragraphs identified by the signal words WARNING and NOTE, with information to help the user avoid improper use of the vehicle and its components. A number of paragraphs identified by the signal word WARNING are also included with information to help avoid procedures and actions which could damage your vehicle. Observe all DANGER and WARNING instructions and indications in this manual, which are identified by the symbols:



Safety of Persons

The total or partial failure to follow these instructions may lead to serious personal injury.



Integrity of the vehicle

The total or partial failure to follow these instructions may lead to serious damage to the vehicle and may even invalidate the warranty.



Safeguarding the Environment

Indicates the correct behaviour to adopt for an environmentally-friendly use of the vehicle.

#### Note

Indicates a note that provides important information to make the process easier and clearer.



## LIST OF TOPICS

<b>GENERAL MANDATORY REQUIREMENTS.....</b>	
GENERAL SAFETY INSTRUCTIONS.....	8
FOREWORD.....	8
MOTORCYCLE CARE.....	8
CARBON MONOXIDE.....	10
FUEL.....	10
HOT PARTS.....	11
INDICATOR LAMPS.....	11
COOLANT.....	11
USED ENGINE OIL AND TRANSMISSION OIL.....	12
BRAKE FLUID.....	12
BATTERY ELECTROLYTE AND HYDROGEN GAS.....	12
STAND.....	13
GENERAL PRECAUTIONS AND WARNINGS.....	13
ROAD TRAFFIC CODE AND VEHICLE USE.....	15
WARRANTY FOR NOISE EMISSIONS.....	15
INFORMATION ON EXHAUST FUMES AND NOISE CONTROL SYSTEM.....	15
POSITIONING OF WARNING LABELS.....	16
KEY TO LABELS.....	17
EVAPORATIVE EMISSION CONTROL SYSTEM.....	19
EMISSION CONTROL SYSTEM WARRANTY STATEMENT - WARRANTY RIGHTS AND OBLIGATIONS.....	21
MANUFACTURER'S WARRANTY COVERAGE.....	21
OWNER'S WARRANTY RESPONSIBILITIES.....	21
<b>VEHICLE.....</b>	
MAIN COMPONENTS DISTRIBUTION.....	26
KEY FOR LOCATION OF MAIN COMPONENTS.....	27
INSTRUMENT CLUSTER.....	28
INSTRUMENT CLUSTER - KEY.....	29
DIGITAL INSTRUMENT PANEL.....	30
INDICATOR LIGHT UNIT.....	30
DIGITAL DISPLAY.....	31
ROAD SCREEN LEGEND.....	32
WARNINGS.....	33
ALARMS.....	35
MAPPING SELECTION.....	38
ELECTRONIC CONTROLS OF THE VEHICLE.....	40
CONTROL BUTTONS.....	47
ADVANCED FUNCTIONS.....	55
CRUISE CONTROL.....	69
ADAPTIVE CRUISE CONTROL F.C.C - FOLLOWING CRUISE CONTROL.....	71
GPS NAVIGATION.....	76
NAVIGATION SCREEN LEGEND.....	78
KEY SWITCH.....	79
IGNITION SWITCH.....	79
ENGAGING THE STEERING LOCK.....	80
HORN BUTTON.....	80
TURN INDICATOR SWITCH.....	80
LIGHT SWITCH.....	80
HIGH BEAM FLASH SWITCH.....	81
DAYTIME/NIGHT LIGHTS SWITCH.....	81
HEATED HANDGRIP CONTROL.....	82
HEATED SADDLE COMMAND.....	82
STARTER BUTTON.....	83
ENGINE STOP SWITCH.....	83
THE IMMOBILIZER SYSTEM.....	83
THE IMMOBILIZER SYSTEM FUNCTION.....	83
THE SADDLE.....	84
SADDLE OPENING.....	84
DOCUMENT / TOOL KIT COMPARTMENT.....	85
USB PORT.....	85
IDENTIFICATION.....	86
WINDSHIELD ADJUSTMENT.....	87
<b>USE.....</b>	
CONTROLS.....	90

## LIST OF TOPICS

REFUELLING.....	91	CLUTCH FLUID LEVEL CHECK.....	124
ADJUSTING THE REAR SHOCK ABSORBERS.....	93	CLUTCH FLUID TOP-UP.....	124
REAR SHOCK ABSORBERS SETTING.....	94	BATTERY.....	124
FRONT FORK ADJUSTMENT.....	96	BATTERY REMOVAL.....	124
SETTING THE FRONT FORK.....	98	ELECTROLYTE LEVEL CHECK.....	125
FRONT BRAKE LEVER ADJUSTMENT.....	99	CHARGING THE BATTERY.....	125
ADJUSTING THE REAR BRAKE PEDAL.....	99	PROLONGED INACTIVITY.....	125
CLUTCH LEVER ADJUSTMENT.....	99	FUSES.....	125
RUNNING-IN.....	100	FRONT LIGHT CLUSTER.....	127
ENGINE STARTER.....	100	HEADLIGHT ADJUSTMENT.....	128
SETTING OFF AND RIDING.....	102	FRONT TURN INDICATORS.....	129
ENGINE STOP.....	104	REAR LIGHT ASSEMBLY.....	129
IT IS EASY TO PARK ANYWHERE ON THE ROAD.....	105	REAR TURN INDICATORS.....	129
CATALYTIC CONVERTER.....	106	REAR-VIEW MIRRORS.....	129
STAND.....	106	FRONT AND REAR DISC BRAKE.....	130
THEFT PREVENTION TIPS.....	107	VEHICLE INACTIVITY.....	132
SAFE RIDING.....	107	VEHICLE CLEANING.....	132
BASIC SAFETY RULES.....	113	TRANSPORT.....	136
<b>MAINTENANCE.....</b>		<b>TECHNICAL DATA.....</b>	
FOREWORD.....	118	DATA.....	138
ENGINE OIL LEVEL.....	118	TOOLKIT.....	140
CHECKING THE ENGINE OIL LEVEL.....	119	<b>SPARE PARTS AND ACCESSORIES.....</b>	
ENGINE OIL TOP-UP.....	120	CAUTION.....	142
ENGINE OIL CHANGE.....	120	<b>SCHEDULED MAINTENANCE.....</b>	
ENGINE OIL FILTER REPLACEMENT.....	120	THE VALUE OF SERVICE.....	144
BEVEL GEAR OIL LEVEL.....	120	SCHEDULED MAINTENANCE.....	144
TYRES.....	120	SCHEDULED MAINTENANCE TABLE.....	144
SPARK PLUG REMOVAL.....	122	RECOMMENDED PRODUCTS.....	147
AIR FILTER REMOVAL.....	122	TABLE OF RECOMMENDED PRODUCTS.....	147
COOLANT LEVEL.....	122		
CHECKING THE COOLANT.....	122		
TOP UP COOLANT.....	122		
BRAKE FLUID LEVEL CHECK.....	123		
TOPPING UP BRAKE FLUID.....	123		

# V100 Mandello - V100 Mandello S



## CHAPTER 01 General mandatory requirements

## General Safety Instructions

### Foreword

N.B.:



THE MAINTENANCE INTERVALS PRESCRIBED BY THE SCHEDULED MAINTENANCE TABLE MUST BE CONSIDERED AS A GENERAL GUIDE FOR USING THE VEHICLE IN NORMAL RUNNING CONDITIONS.

IT MAY BE NECESSARY TO REDUCE THE MAINTENANCE INTERVALS UNDER SOME PARTICULAR CONDITIONS. ESPECIALLY WHEN USED IN GEOGRAPHICAL LOCATIONS WITH ADVERSE CLIMATIC CONDITIONS, USE ON UNEVEN GROUND OR SEVERE INDIVIDUAL USE.

N.B.:



IF THE VEHICLE FALLS, WHETHER WHILE MOVING OR STATIONARY, ALWAYS TAKE IT TO AN OFFICIAL **Moto Guzzi** DEALER, WHICH WILL

**CHECK IT THOROUGHLY TO MAKE SURE THAT IT IS UNDAMAGED AND IN PERFECT WORKING ORDER.**

N.B.:



**THIS USE AND MAINTENANCE MANUAL IS AN IMPORTANT DOCUMENT AND MUST ALWAYS BE KEPT WITH THE VEHICLE.**

**IF THE VEHICLE IS RESOLD, PLEASE PROVIDE THIS MANUAL TO THE NEW OWNER.**

**Moto Guzzi** has created this use and maintenance manual to provide you, the user, with correct and updated information. However, considering the fact that **Moto Guzzi** is constantly improving the design of its vehicles, there may be slight differences between the characteristics of the vehicle in your possession and the information contained in this use and maintenance manual. For any questions concerning your vehicle, contact your local official **Moto Guzzi** dealer who will always be updated with the latest information available from the company. For checks and repairs not expressly described in this use and maintenance manual, for the purchase of original spare parts, accessories and other **Moto Guzzi** products, as well as support on specific problems, please contact your local

**Moto Guzzi** dealer. These professionals will provide you a quick and accurate service.

Thank you for choosing **Moto Guzzi**.

We wish you a pleasant ride!

This use and maintenance manual is copyright protected in all countries, and total or partial reproduction by any print or electronic means is strictly prohibited.

### Motorcycle care

**Moto Guzzi** recommends using quality products for cleaning the vehicle. The use of unsuitable products can damage vehicle components. For cleaning do not use solvents such as "nitro thinner", "cold cleaning agents", fuels or the like, or cleaning products that contain alcohol.

### WASHING THE MOTORCYCLE

**Moto Guzzi** recommends softening with water and then carefully removing the insects and stubborn stains before washing the vehicle.

To prevent stains, do not wash the motorcycle immediately after exposure to sunlight, and do not wash it in the sun.

If the vehicle is used during the winter months, be sure to frequently wash the motorcycle. To remove anti-icing salt sprayed on roads in the winter, wash the motorcycle with cold water immediately after use.

**CAUTION**



AFTER CLEANING YOUR MOTORCYCLE, THE EFFICIENCY OF THE BRAKING SYSTEM MAY BE TEMPORARILY AFFECTED DUE TO THE PRESENCE OF WATER ON THE FRICTION SURFACES. CONSIDER AN INCREASE IN BRAKING SPACE, OPERATE THE BRAKES REPEATEDLY TO RESTORE NORMAL CONDITIONS. CARRY OUT THE PRE-RIDE CHECKS BEFORE USE.

**WARNING**

USE OF HOT WATER INTENSIFIES THE EFFECT OF THE SALT. USE ONLY PLENTY OF COLD WATER TO WASH AND REMOVE ANTI-ICING SALT.

**WARNING**

USE OF HIGH PRESSURE WASHING SYSTEMS (OR STEAM CLEANERS) CAN DAMAGE THE SEALS, OIL SEALS, BRAKING SYSTEM, ELECTRICAL SYSTEM AND THE SADDLE. DO NOT USE STEAM

OR HIGH PRESSURE CLEANING SYSTEMS. DO NOT USE STEAM OR HIGH PRESSURE WASHING SYSTEMS. DO NOT INSIST WITH THE PRESSURE NOZZLE ON THE STEERING BEARING, WHEEL BEARINGS, INSIDE THE REAR WHEEL HUB, ON THE HYDRAULIC BRAKING CIRCUIT AND ON THE ELECTRICAL PARTS.

**CLEANING OF SENSITIVE PARTS  
BODYWORK**

To keep the motorcycle bright, wash it regularly, especially if used in areas with high levels of pollution or mud. Stubborn stains of tree resin, petrol, oil, brake liquid or bird droppings should be removed immediately, otherwise the stains risk becoming permanent.

After washing it is easy to identify marks and residual stains, remove them from the body using a soft cloth and brand-name, non-abrasive polish, and protect with a protective wax for cars. Periodic care, a thorough cleaning and regular protective wax for the bodywork preserves the aesthetic quality of the motorcycle over the long term.

**PLASTIC COMPONENTS****WARNING**

IF THE PLASTIC COMPONENTS ARE CLEANED USING AGGRESSIVE AGENTS, THE SURFACE MAY BE DAMAGED. DO NOT USE CLEANING PRODUCTS CONTAINING ALCOHOL, SOLVENTS OR THAT ARE ABRASIVE FOR THE CLEANING OF PLASTIC PARTS. ROTARY BRUSHES OR SPONGES WITH HARD SURFACES CAN MAKE SCRATCHES.

**CHROME PARTS AND POLISHED METAL****WARNING**

TREAT THE PARTS MADE OF CHROME, ALUMINIUM OR POLISHED STEEL IN A SPECIAL MANNER. WASH THEM WITH PLENTY OF WATER AND CAR SHAMPOO, POLISH AND REGULARLY BRIGHTEN THEM WITH POLISH PASTE, PROTECT THEM WITH WAXES OR SUITABLE ACID-FREE PRODUCTS (E.G. VASELINE).

**RADIATOR****WARNING**

**IF THE VEHICLE IS USED IN WINTER ON ROADS TREATED WITH SALT, WASH THE RADIATOR FREQUENTLY TO PREVENT COSMETIC DAMAGE TO THE FINISH AND THE RISK OF ENGINE OVERHEATING. WASH WITH PLENTY OF WATER. WASH WITH A LOW PRESSURE JET OF WATER, USING A GARDEN HOSE FOR EXAMPLE.**

### RUBBER PARTS

Clean the rubber parts using water and mild shampoo (brand-name, suitable for car bodies)

### WARNING



**THE USE OF SILICONE SPRAY TO CLEAN THE RUBBER SEALS MAY CAUSE DAMAGE. DO NOT USE OTHER PRODUCTS CONTAINING SILICON FOR CLEANING THE MOTORCYCLE.**

### Carbon monoxide

If it is necessary to run the engine for maintenance work, make sure the area where you are working is well ventilated. **Never leave the engine running in closed places.**

If it is necessary to work indoors, use an exhaust extraction system.

### CAUTION



**EXHAUST EMISSIONS CONTAIN CARBON MONOXIDE, A POISONOUS GAS WHICH CAN CAUSE LOSS OF CONSCIOUSNESS AND EVEN DEATH.**

### CAUTION



**CARBON MONOXIDE IS ODOURLESS AND COLOURLESS, THEREFORE IT CANNOT BE DETECTED BY SMELL, SIGHT OR OTHER SENSES. DO NOT BREATHE IN EXHAUST FUMES UNDER ANY CIRCUMSTANCES.**

### Fuel

Keep the petrol out of the reach of children. Petrol is toxic. Do not use the mouth to siphon the petrol. Avoid contact of the petrol with the skin. If you should accidentally come into contact with petrol, change your clothes immediately and wash the area where petrol has been spilled thoroughly with soap and warm water. Should you accidentally ingest petrol, do not induce

vomiting. Drink plenty of fresh water or milk and consult a doctor immediately.

If petrol should inadvertently come into contact with the eyes, rinse thoroughly with clean, fresh water and consult a doctor immediately.

### CAUTION



**FUEL USED TO DRIVE EXPLOSION ENGINES IS HIGHLY INFLAMMABLE AND CAN BECOME EXPLOSIVE UNDER SPECIFIC CONDITIONS. IT IS THEREFORE RECOMMENDED TO CARRY OUT REFUELLING AND MAINTENANCE PROCEDURES IN A VENTILATED AREA WITH THE ENGINE SWITCHED OFF. DO NOT SMOKE DURING REFUELLING AND NEAR FUEL VAPOURS, AVOIDING ANY CONTACT WITH NAKED FLAMES, SPARKS OR OTHER SOURCES WHICH MAY CAUSE THEM TO IGNITE OR EXPLODE.**

**DO NOT DISPERSE FUEL IN THE ENVIRONMENT. ALWAYS USE APPROPRIATE DISPOSAL METHODS.**

**KEEP OUT OF THE REACH OF CHILDREN .**

## Hot parts

The engine and the exhaust system components get very hot and remain in this condition for a certain time interval after the engine has been switched off. Before handling these components, make sure that you are wearing insulating gloves or wait until the engine and the exhaust system have cooled down.

## Indicator lamps

### WARNING



IF THE WARNING LIGHTS COME ON DURING NORMAL ENGINE OPERATION, THE ELECTRONIC CONTROL UNIT HAS DETECTED A FAULT.

### WARNING



IF THE ALARM OIL PRESSURE LAMP FLASHES DURING NORMAL ENGINE OPERATION, IT MEANS THAT THE OIL PRESSURE IN THE CIRCUIT IS TOO LOW. IN THIS CASE, IT IS MANDATORY TO SWITCH OFF THE

**ENGINE IMMEDIATELY IN ORDER TO PREVENT DAMAGE.**

### WARNING



PERFORM THE MOTOR OIL LEVEL CHECK. IF THE INSUFFICIENT MOTOR OIL PRESSURE LIGHT REMAINS DESPITE THE ABOVE PROCEDURE BEING PERFORMED CORRECTLY, CONTACT AN AUTHORIZED Moto Guzzi Dealer TO HAVE THE SYSTEM CHECKED.

## Coolant

Coolant contains ethylene glycol, which may be flammable in certain conditions. Ethylene glycol burns with an invisible flame which may still cause burns.

### CAUTION



TAKE PARTICULAR CARE NOT TO SPILL COOLANT ONTO HOT PARTS OR THE ENGINE AND EXHAUST SYSTEM; THE FLUID MAY IGNITE AND BURN WITH AN INVISIBLE FLAME. WHEN CARRYING OUT MAINTENANCE

OPERATIONS, IT IS ADVISABLE TO WEAR LATEX GLOVES. WHILE POISONOUS, COOLANT HAS A SWEET TASTE WHICH MAKES IT EXTREMELY APPEALING TO ANIMALS. NEVER LEAVE COOLANT IN OPEN CONTAINERS WHERE IT MAY BE REACHED AND DRUNK BY AN ANIMAL.

KEEP OUT OF THE REACH OF CHILDREN. NEVER REMOVE THE RADIATOR CAP WHILE THE ENGINE IS STILL HOT.

COOLANT IS UNDER PRESSURE AND MAY CAUSE BURNS.

### CAUTION



COOLANT IS TOXIC IF INGESTED; CONTACT WITH YOUR EYES OR SKIN MAY CAUSE IRRITATION. IF THE FLUID GETS IN CONTACT WITH THE EYES OR SKIN, RINSE REPEATEDLY WITH PLENTY OF WATER AND SEEK MEDICAL ADVICE.

IF SWALLOWED, INDUCE VOMITING, RINSE THE MOUTH AND THROAT WITH PLENTY OF WATER AND SEEK MEDICAL ADVICE IMMEDIATELY.

**RISK OF BURNS: NEVER REMOVE THE RADIATOR CAP WHILE THE ENGINE IS HOT. WITH THE ENGINE AND COOLANT AT OPERATING TEMPERATURE, THE COOLANT WILL BE UNDER PRESSURE. REMOVING THE RADIATOR CAP WHEN THE ENGINE IS HOT COULD CAUSE HOT COOLANT TO ESCAPE WITHOUT WARNING UNDER PRESSURE, WITH THE RISK OF POSSIBLE BURNS. WAIT UNTIL THE ENGINE HAS COOLED COMPLETELY BEFORE UNSCREWING AND REMOVING THE RADIATOR CAP.**

Used engine oil and transmission oil

**CAUTION**



**WHEN CARRYING OUT MAINTENANCE OPERATIONS, IT IS ADVISABLE TO WEAR PROTECTIVE IMPERMEABLE GLOVES.**

**THE ENGINE OR GEARBOX OIL MAY CAUSE SERIOUS INJURIES TO THE SKIN IF HANDLED FOR PROLONGED PERIODS OF TIME AND ON A REGULAR BASIS. WASH YOUR HANDS CAREFULLY AFTER HANDLING OIL.**

**ALWAYS MAKE USE OF APPROPRIATE DISPOSAL METHODS. OIL IS DANGEROUS FOR THE**

**ENVIRONMENT AND FEDERAL LAW FORBIDS ITS DISPOSAL WITHOUT AUTHORISATION. TAKE THE WASTE OIL TO A SPECIAL COLLECTION CENTRE OR ASK FOR IT TO BE COLLECTED BY THE NEAREST WASTE OIL RECOVERY COMPANY.**

**DO NOT DISPOSE OF OIL INTO THE ENVIRONMENT.**

**KEEP OUT OF THE REACH OF CHILDREN.**

Brake fluid

**WARNING!**



**BRAKE FLUID IS EXTREMELY POISONOUS. NEVER ALLOW BRAKE FLUID TO BE INGESTED OR SWALLOWED. IF ACCIDENTALLY SWALLOWED, DRINK LARGE QUANTITIES OF MILK OR WATER AND SEEK MEDICAL ADVICE IMMEDIATELY. BRAKE FLUID IS HIGHLY DESTRUCTIVE TO SKIN AND EYE TISSUE. IF YOU ACCIDENTALLY SPILL BRAKE FLUID ON YOURSELF, TAKE OFF YOUR CLOTHES, WASH WITH HOT WATER AND SOAP AND SEEK MEDICAL ADVICE IMMEDIATELY. IF BRAKE FLUID GETS ACCIDENTALLY IN CONTACT WITH**

**YOUR EYES, RINSE WITH ABUNDANT FRESH WATER AND SEEK MEDICAL ADVICE IMMEDIATELY. KEEP BRAKE FLUID OUT OF THE REACH OF CHILDREN.**

**CAUTION**



**BRAKE FLUID CAN DAMAGE PAINT FINISH, PLASTIC AND RUBBER. WHEN SERVICING THE BRAKING SYSTEM, PROTECT THESE COMPONENTS WITH A CLEAN CLOTH. ALWAYS WEAR PROTECTIVE GOGGLES WHEN SERVICING THESE SYSTEMS. BRAKE FLUID IS EXTREMELY HARMFUL FOR THE EYES. IN THE EVENT OF ACCIDENTAL CONTACT WITH THE EYES, RINSE THE EYES IMMEDIATELY WITH PLENTY OF COOL, CLEAN WATER AND SEEK IMMEDIATE MEDICAL ATTENTION.**

**KEEP OUT OF THE REACH OF CHILDREN .**

Battery electrolyte and hydrogen gas

(if applicable)

**CAUTION**



THE BATTERY ELECTROLYTE IS TOXIC, CORROSIVE AND, AS IT CONTAINS SULPHURIC ACID, MAY CAUSE BURNING IF IT COMES INTO CONTACT WITH THE SKIN. WHEN HANDLING BATTERY ELECTROLYTE, WEAR TIGHT-FITTING GLOVES AND PROTECTIVE APPAREL. IN THE EVENT OF SKIN CONTACT WITH THE ELECTROLYTIC FLUID, RINSE WELL WITH PLENTY OF CLEAN WATER. IT IS PARTICULARLY IMPORTANT TO PROTECT YOUR EYES BECAUSE EVEN TINY AMOUNTS OF BATTERY ACID MAY CAUSE BLINDNESS. IF THE FLUID GETS INTO CONTACT WITH THE EYES, WASH WITH ABUNDANT WATER FOR FIFTEEN MINUTES AND CONSULT AN EYE SPECIALIST IMMEDIATELY. THE BATTERY RELEASES EXPLOSIVE GASES; KEEP IT AWAY FROM FLAMES, SPARKS, CIGARETTES OR ANY OTHER HEAT SOURCES. ENSURE ADEQUATE VENTILATION WHEN SERVICING OR RECHARGING THE BATTERY.

KEEP OUT OF THE REACH OF CHILDREN .

BATTERY LIQUID IS CORROSIVE. DO NOT POUR OR SPREAD IT ESPECIALLY ON PLASTIC PARTS. ENSURE THAT THE ELECTROLYTIC

**ACID IS COMPATIBLE WITH THE BATTERY BEING ACTIVATED.**

### Stand

#### CAUTION



DO NOT SIT ON THE VEHICLE WHILE STATIONARY ON THE SIDE STAND. THE PARKING STAND IS EXCLUSIVELY DESIGNED TO KEEP THE VEHICLE BALANCED. THE ADDITIONAL WEIGHT OF A RIDER, PASSENGER OR BOTH COULD CAUSE THE VEHICLE TO FALL, RESULTING IN SERIOUS INJURY OR DEATH.

**BEFORE MOVING THE VEHICLE:**

CHECK THAT THE SIDE STAND AND/OR THE CENTRAL STAND (IF PROVIDED) ARE COMPLETELY RAISED. IF THE STANDS ARE NOT FULLY RAISED, THIS MAY BE SERIOUS INJURY OR DEATH.

## General precautions and warnings

### DANGER OF OVERHEATING

WHEN THE VEHICLE IS STATIONARY, DO NOT KEEP THE ENGINE RUNNING

MORE THAN NECESSARY, THIS MAY CAUSE EXCESSIVE OVERHEATING. IN EXTREME CASES, RISK OF FIRE.

- WHEN THE VEHICLE IS STATIONARY, DO NOT UNNECESSARILY RUN THE ENGINE.
- TO PREVENT DAMAGE FROM EXCESSIVE OVERHEATING, AUTOMATIC ENGINE SHUT-DOWN IS PROVIDED FOR LONG STAYS IN NEUTRAL, AT IDLE SPEED, AND IN EXTREMELY HOT CONDITIONS. IN ANY CASE, EVEN AFTER THE AUTOMATIC SHUT-DOWN, THE ENGINE CAN BE SWITCHED ON AGAIN IMMEDIATELY.
- START IMMEDIATELY AFTER IGNITION, MAKING SURE TO RIDE A SHORT INITIAL DISTANCE AT LOW RPM.
- AFTER USE, AS SOON AS PARKED, THE ENGINE MUST BE IMMEDIATELY TURNED OFF.
- AFTER USE, DO NOT PLACE OBJECTS IN CONTACT WITH THE VEHICLE, WHEN IT IS STILL HOT, AS THEY COULD IGNITE (E.G. PROTECTIVE FABRICS, JACKET, ETC.).
- IF THE ENGINE TEMPERATURE IS VERY HIGH, IT IS POSSIBLE THAT THE COOLING FAN WILL CONTINUE TO RUN FOR SEVERAL SECONDS EVEN AFTER THE ENGINE HAS BEEN SWITCHED OFF. THIS BEHAVIOUR IS NOT TO BE

CONSIDERED ABNORMAL, IT'S A STRATEGY SPECIFICALLY CREATED TO PROTECT THE ENGINE.

**TAMPERING**

- NEVER TAMPER WITH ANY PART OF THE MOTORCYCLE (E.G. ENGINE CONTROL UNIT, THROTTLE VALVES, CLUTCH, EXHAUST SYSTEM, ETC.). THIS MAY CAUSE DAMAGE TO THE COMPONENTS INVOLVED, FAILURE OF RELEVANT SAFETY FUNCTIONS AND LOSS OF THE WARRANTY.

**DANGER OF BURNS**

IN CASE OF OVERHEATING OF THE ENGINE AND EXHAUST SYSTEMS WHILE RUNNING, PAY PARTICULAR ATTENTION:

- DANGER OF BURNS.
- AFTER TURNING OFF THE VEHICLE, PAY ATTENTION THAT NO PERSON OR OBJECT COMES IN CONTACT WITH THE ENGINE AND THE EXHAUST SYSTEM.

Unless otherwise specified in this Use and Maintenance Manual, do not remove any mechanical or electrical component.

**WARNING**



**SOME OF THE CONNECTORS ON THE VEHICLE MAY BE ACCIDENTALLY SWAPPED, AND MAY COMPROMISE NORMAL VEHICLE OPERATION AND/OR CAUSE IRREPARABLE DAMAGE TO PARTS OF THE VEHICLE IF INCORRECTLY INSTALLED.**

If you have any questions regarding your warranty rights and responsibilities, please contact Piaggio Group Americas, Inc., 860 Washington Street, 9th Floor, New York, NY 10014 U.S.A. Telephone number: (212) 380 4400, email: [customercare@us.piaggio.com](mailto:customercare@us.piaggio.com), the U.S. Environmental Protection Agency, 2000 Traverwood Ann Arbor, MI 48105 or the California Air Resources Board at P.O. Box 8001, 9528 Telstar Avenue, El Monte, CA 91734-8001.

If it is found that your vehicle has a defect that could cause an accident, injury or death, immediately report it to NHTSA (**National Highway Traffic Safety Administration**) and **Moto Guzzi**. If NHTSA receives other similar information, it could initiate an investigation, and if a safety defect is found affecting a group of vehicles it could request its withdrawal or the application of corrective measures. In any case, the NHTSA does not intervene in the event of individual problems between persons, dealers or **Moto Guzzi**. To contact NHTSA, call the **Vehicle Safety Hotline** toll-free number (888 327 4236) or write to: U.S. Department of Transportation, National

Highway Safety Administration, 1200 New Jersey Ave., SE, Washington DC 20590. For more information regarding vehicle safety, call the toll-free number.

Your safety and that of the persons around you depends not only on your driving skills, but also on your knowledge of the vehicle and the safety rules.

Therefore, it is essential not to use the vehicle on public roads or highways before having received instructions from a qualified and prepared safety organization, for example **MOTORCYCLE SAFETY FOUNDATION**.

**LIST OF DEFECTS THAT COMPROMISE THE SAFETY**

If it is found that your vehicle has a defect that could cause an accident or death, immediately report it to the National Highway Traffic Safety Administration (NHTSA), a section of the American Department of Transportation. After receiving information on alleged defects, NHTSA could open an investigation to find out if there is a group of defective vehicles on the market. At that point, it could launch an information campaign and recall the vehicles from the market. However, neither the NHTSA nor the Department of Transportation will be involved in personal matters regarding the consumer and manufacturer.

Additional information can be obtained by calling the specified number.

## Road traffic code and vehicle use

The road traffic code rules vary from state to state. It is extremely important to know in advance the road traffic code rules of the country where the vehicle will be used.

### CAUTION



**THIS VEHICLE HAS BEEN DESIGNED TO BE USED ON ASPHALT ROADS ONLY. IT WAS NOT DESIGNED TO BE USED ON OFF-ROAD TRACKS, RACE CIRCUITS, OFF-ROAD OR FOR MOTOCROSS COMPETITIONS.**

**DO NOT RIDE THIS VEHICLE ON UNEVEN SURFACES, DIRT OR GRAVEL ROADS. FAILURE TO FOLLOW THESE WARNINGS COULD LEAD TO A FALL WITH CONSEQUENT INJURIES, EVEN DEATH.**

## Warranty for noise emissions

**Piaggio & Co. S.p.A** warrants that the exhaust system complies with all **US EPA** federal noise emission standards in effect at the time of production. Any questions concerning the exhaust system of this vehicle must be addressed to any authorised **Moto Guzzi** dealer or to the **Moto Guzzi** Customer Care by calling (212) 380 4400, or by writing to:

**Moto Guzzi Customer Care c/o Piaggio Group Americas, Inc.**

860 Washington Street, 9th Floor,

New York, NY 10014

U.S.A.

email: [customercare@us.piaggio.com](mailto:customercare@us.piaggio.com)

## Information on exhaust fumes and noise control system

### Origins of emissions

### CAUTION



**THE COMBUSTION PROCESS PRODUCES CARBON MONOXIDE AND HYDROCARBONS. THE CONTROL OF HYDROCARBONS IS VERY IMPORTANT BECAUSE UNDER CERTAIN CONDITIONS THEY REACT TO EXPOSURE TO SUNLIGHT AND PRODUCE PHOTO-CHEMICAL SMOG.**

**WHILE CARBON MONOXIDE DOES NOT REACT IN THE SAME WAY AS HYDROCARBONS, IT IS HIGHLY TOXIC AND HARMFUL. Moto Guzzi USES A CARBURETTOR ADJUSTMENT SET TO A "LEAN" MIXTURE AND OTHER SYSTEMS TO REDUCE**

## THE PRODUCTION OF CARBON MONOXIDE AND HYDROCARBONS.

### Tampering

It is forbidden to tamper the noise control system. The following actions are prohibited by federal law:

a) The removal and any action, by anyone, aimed at rendering inoperative, except for maintenance, repair or replacement, any device or design element incorporated in all new vehicles, in order to control the noise emission before sale or delivery of the vehicle to the final purchaser or while it is being used,

or

b) the use of the vehicle after this device or design element has been removed or rendered inoperative by any person.

These tampering actions also include the actions listed below:

a) Removal or perforation of the silencer, deflectors, manifold pipes or any other component for conveying the exhaust gases.

b) Disassembly or perforation of any component of the intake system.

c) Insufficient proper maintenance.

d) Replacement of any moving part of the vehicle or parts of the intake or exhaust system with parts other than those specified by the manufacturer.

e) Removal of decals or warning labels regarding emissions or safe vehicle operation. **ANY DAMAGE RESULTING FROM THE REMOVAL OF THE DECALS AND/OR THE WARNING LABELS WILL NOT BE COVERED BY THE TERMS OF THE Moto Guzzi LIMITED WARRANTY FOR NEW VEHICLES.** Besides, many countries may refuse to grant registration of a vehicle that does not have the necessary emission and/or safety warning labels if these are not regularly attached to the vehicle. The vehicle owner must consider that **Piaggio Group Americas, Inc. / Moto Guzzi USA** will not recognise any warranty if the vehicle or any of its components is damaged or defective due to negligence, improper

### Positioning of warning labels

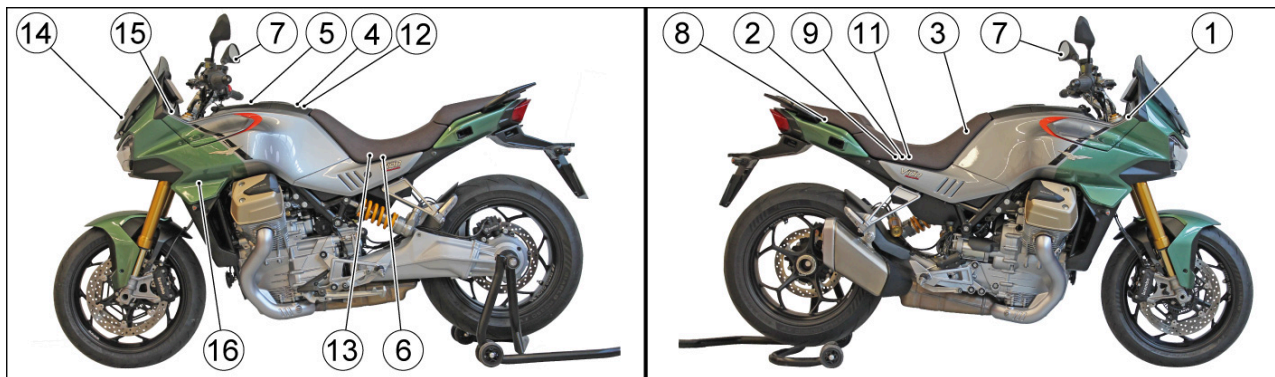

maintenance, unauthorized modifications, use in organised or non-organised competitions or in events such as Track Days.

#### WARNING



**THIS PRODUCT SHOULD BE REPAIRED OR REPLACED IF THE NOISE FROM THE VEHICLE INCREASES SIGNIFICANTLY DURING USE. OTHERWISE, THERE WILL BE SANCTIONS IMPOSED AGAINST THE OWNER IN ACCORDANCE WITH STATE OR LOCAL LAWS.**

#### Problems affecting emissions

If one of the following symptoms are experienced, have the vehicle checked and repaired immediately by your local **Moto Guzzi** dealer.

#### Symptoms:

- Difficulty starting, or stalling the engine after starting.
- Unstable idle speed.
- Ignition problems, misfire during acceleration. Pre-ignition/pinking
- Manoeuvring difficulties.
- Poor engine performance, reduced handling or excessive fuel consumption.

## Key to labels

### License plate 1

- Plate only on the America version vehicle.

<input type="checkbox"/> MFD BY MOTO GUZZI DIVISION OF PIAGGIO & C. S.p.A. THIS VEHICLE CONFORMS TO ALL APPLICABLE U.S. FEDERAL MOTOR VEHICLE SAFETY STANDARDS IN EFFECT ON THE DATE OF MANUFACTURE SHOWN ABOVE VIN: <input type="text"/> <input type="checkbox"/> TYPE: MOTORCYCLE	<input type="checkbox"/> GVWR ??? KG (??? LB) <input type="checkbox"/> GAWR F. ??? KG (??? LB) WITH ?????- ??? ??? TIRE AND 1.?? x ?? MT DOT RIM AT ??? KPA (?? PSI) COLD <input type="checkbox"/> GAWR R. ??? KG (??? LB) WITH ?????- ??? ??? TIRE AND 1.?? x ?? MT DOT RIM OR ?????- ??? ??? TIRE AND 1.?? x ?? MT DOT RIM AT ??? KPA (?? PSI)
--	--

### USA

- Plate only on the Canada version vehicle.

<input type="checkbox"/> MFD BY / FABRIQUE PAR: <input type="text"/> GVWR / PNBE: ??? KG FRONT / AVANT GAWR / PNBE: ??? KG REAR / ARRIERE GAWR / PNBE: ??? KG THIS VEHICLE CONFORMS TO ALL APPLICABLE STANDARDS PRESCRIBED UNDER THE CANADIAN MOTOR VEHICLE SAFETY REGULATIONS IN EFFECT ON THE DATE OF MANUFACTURE. CE VEHICULE EST CONFORME A TOUTES LES NORMES QUI LUI SONT APPLICABLES EN VERTU DU RELEMENT SUR LA SECURITE DES VEHICULES AUTOMOBILES DU CANADA EN VIGUEUR A LA DATE DE SA FABRICATION. VIN / NIV: <input type="text"/> <input type="checkbox"/> TYPE: MC	<input type="checkbox"/> MOTO GUZZI DIVISION OF PIAGGIO & C. S.p.A. -???.
---	--

### CDN

### License plate 2

HOSE ROUTING DIAGRAM  
 EVAP FAMILY: ??????????????  
 MOTO GUZZI DIVISION OF  
 PIAGGIO & C. S.p.A.  
 -???-

## CARBON CANISTER SCHEME

### License plate 3

**⚠ WARNING!**

*Do not use any tire other than those recommended and approved by Moto Guzzi. Maintain proper tire inflation. Do not use any tire with less than 1/8" (3mm) tread remaining. Do not repair any tire, nor use a repaired tire. Do not ride your motorcycle overloaded or with an unbalanced load. Failure to follow these warnings can lead to an accident and serious injuries or death. See owner's manual.*

-???- MOTO GUZZI

	Tires pressure kPa - (psi)		Tires size	Front tire	
	Front tire	Rear tire		??????	??????
	???	???	Tires size	??????	??????
	(??)	(??)		??????	??????
	???	???		??????	??????
	???	???		??????	??????

### License plate 4

**⚠ WARNING!**

**DO NOT ALLOW KEY CHAIN AND ANY OTHER ITEM TO FALL BETWEEN THE STEERING HEAD AND THE BODY OF MOTORCYCLE. THIS CAN CAUSE LOSS OF CONTROL.**

### License plate 5

**⚠ WARNING!**

*Never install accessories or replacement parts not approved by Moto Guzzi as original equipment. This can degrade the handling and safety of your motorcycle, and can cause an upset with subsequent accident and serious injury or even death. The stability and safety of any motorcycle is adversely affected by the addition of any load carrying accessory. See owner's manual.*

### License plate 6

**⚠ WARNING!**

*Contain sulfuric acid which can cause severe injuries. Avoid contact with skin, eyes or clothing. Antidote: EXTERNAL - Flush with water. INTERNAL - Drink large quantities of water or milk. Follow with milk of magnesia, beaten egg or veg. oil. Call physician immediately. Eyes: Flush with water for 15 minutes and get prompt medical attention. KEEP OUT OF REACH OF CHILDREN. Batteries produce explosive gases. Keep sparks, flames, cigarettes away. Charge only in well-ventilated space. Always wear protective goggles when working around batteries. Always connect the battery vent tube. Failure to heed this warning will cause corrosion of the electrical system.*

### License plate 7





Plate 15

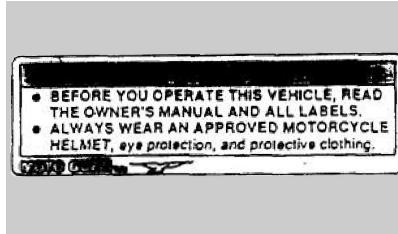
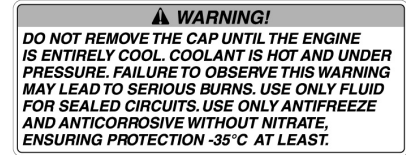
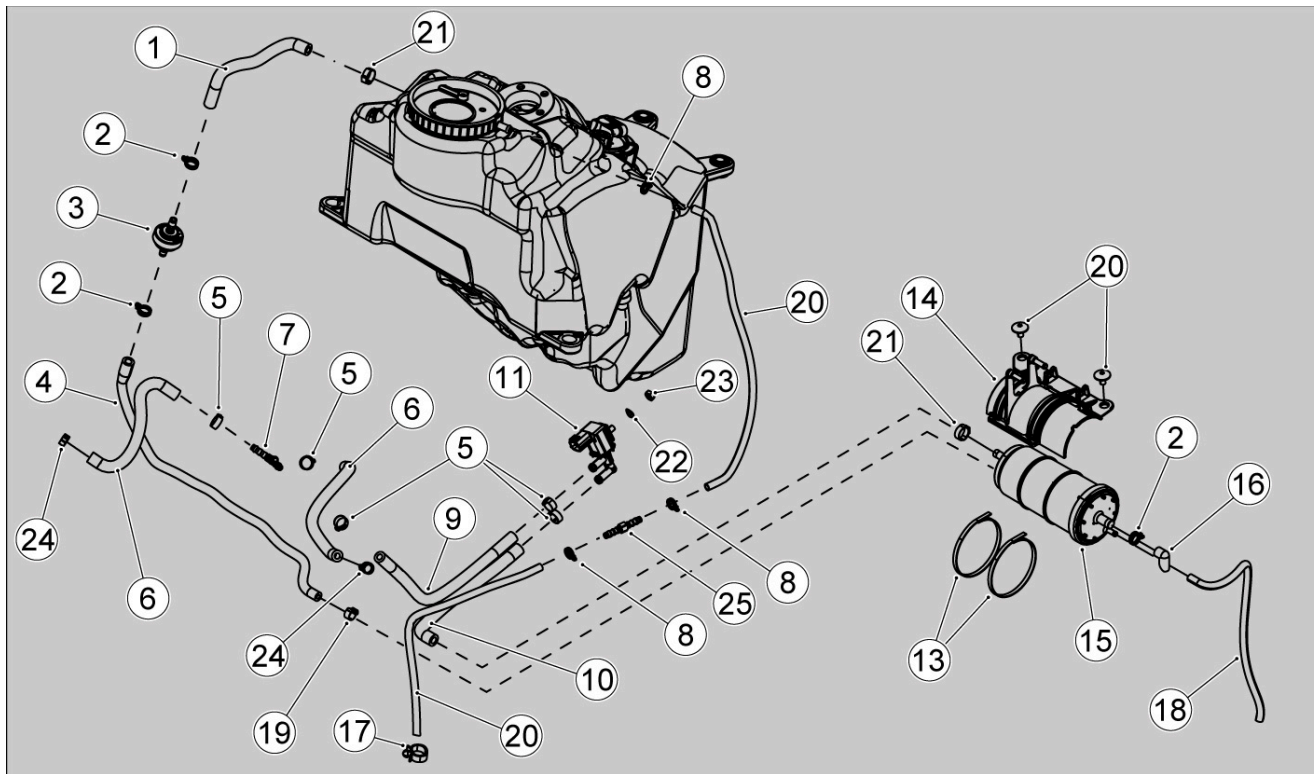

Plate 16



## Evaporative emission control system

# 1 General mandatory requirements



## Key

- |                     |                                 |                                   |
|---------------------|---------------------------------|-----------------------------------|
| 1 . Tank-valve pipe | 4 . Valve-canister pipe         | 10 . Solenoid valve-canister pipe |
| 2 . Pipe clamp      | 5 . Clamp 12.5x8                | 11 . Complete air solenoid valve  |
| 3 . Safety valve    | 6 . SAE 30 pipe, diam.12.7x6.35 | 12 . Special screw                |
|                     | 7 . 3-way fitting               | 13 . 4.5X280 clamp                |
|                     | 8 . Clamp D11,3                 | 14 . Support                      |
|                     | 9 . Solenoid valve-fitting pipe | 15 . Canister                     |

- 16 .Ventilation pipette
- 17 .Molletta L. 22 mm
- 18 .Pipe 4x8
- 19 .Pipe clamp
- 20 .Pipe 5.5x10
- 21 .White snap-on clamp diam.13x6
- 22 .Curved spring washer
- 23 .M6 nut
- 24 .Green click clamp Dia. 11x6.6x1
- 25 .Joint

## EMISSION CONTROL SYSTEM WARRANTY STATEMENT - WARRANTY RIGHTS AND OBLIGATIONS

### Model Year 2026

The United States Environmental Protection Agency, the California Air Resources Board and **Moto Guzzi Division of Piaggio & C. S.p.A.** (hereinafter **Moto Guzzi**) are pleased to explain the emission control system warranty on your motorcycle. In California, new motor vehicles must be designed, built and equipped to meet the stringent anti-smog standards issued by the State. **Moto Guzzi** must warrant the emission control system on your motorcycle for the periods of time listed below provided there has been no abuse, neglect or improper maintenance of your motorcycle.

Your emission control system may include parts such as the carburettor or fuel injection system, the ignition system, catalytic

converter and engine computer. Also included may be hoses, belts, connectors and other emission-related assemblies.

Where a warrantable condition exists, **Moto Guzzi** will repair your motorcycle at no cost to you, including diagnosis, parts and labor.

### MANUFACTURER'S WARRANTY COVERAGE

Class I-A motorcycles (0-49 cc): for a period of use of five (5) years or 6,000 kilometers (3,750 miles), whichever first occurs.

Class I-B motorcycles (50-169 cc): for a period of use of five (5) years or 12,000 kilometers (7,456 miles), whichever first occurs.

Class II motorcycles (170-279 cc): for a period of use of five (5) years or 18,000 kilometers (11,185 miles), whichever first occurs.

Class III motorcycles (280 cc and larger): for a period of use of five (5) years or 30,000 kilometers (18,641 miles), whichever first occurs.

If an emission-related part on your motorcycle is defective, the part will be repaired or replaced by **Moto Guzzi**. This is your emission control system DEFECTS WARRANTY.

### **Moto Guzzi - Limited Warranty on Emission Control System**

**Moto Guzzi** warrants that each new motorcycle, that includes as standard

equipment a headlight, taillight and stoplight, and is street legal:

**A.** is designed, built and equipped so as to conform at the time of initial retail purchase with all applicable regulations of the United States Environmental Protection Agency, and the California Air Resources Board; and

**B.** is free from defects in materials and workmanship which cause such motorcycle to fail to conform with applicable regulations of the United States Environmental Protection Agency or the California Air Resources Board for a period of use, depending on the engine displacement, 6,000 kilometers (3,750 miles), if the motorcycle's engine displacement is less than 50 cubic centimeters, of 12,000 kilometers (7,456 miles), if the motorcycle's engine displacement is equal to or greater than 50 cubic centimeters but less than 170 cubic centimeters; of 18,000 kilometers (11,185 miles), if the motorcycle's engine displacement is equal to or greater than 170 cubic centimeters but less than 280 cubic centimeters; or of 30,000 kilometers (18,641 miles), if the motorcycle's engine displacement is 280 cubic centimeters or greater; or 5 (five) years from the date of initial retail delivery, whichever first occurs.

### OWNER'S WARRANTY RESPONSIBILITIES

- As the motorcycle owner, you are responsible for the performance of the required maintenance listed in your owner's

manual. **Moto Guzzi** recommends that you retain all receipts covering maintenance on your motorcycle, but Moto Guzzi cannot deny warranty solely for the lack of receipts or for your failure to ensure the performance of all scheduled maintenance.

- You are responsible for presenting your motorcycle to a **Moto Guzzi** dealer as soon as a problem exists. The warranty repairs should be completed in a reasonable amount of time, not to exceed 30 days.

- As the motorcycle owner, you should be aware that Moto Guzzi may deny your warranty coverage if your motorcycle or a part has failed due to abuse, neglect, improper maintenance or unapproved modifications.

If you have any questions regarding your warranty rights and responsibilities, you should contact **Piaggio Group Americas, Inc.**, 860 Washington Street, 9th Floor, New York, NY 10014 (phone: (212) 380 4400) (email: [customercare@us.piaggio.com](mailto:customercare@us.piaggio.com)), or the **U.S. Environmental Protection Agency**, 2000 Traverwood Ann Arbor, MI 48105, or the **California Air Resources Board**, 4001 Iowa Avenue, Riverside, CA 92507.

## I - COVERAGE

Warranty defects shall be remedied during customary business hours at any authorized **Moto Guzzi** motorcycle dealer located within the United States of America in compliance with the Clean Air Act and

applicable regulations of the United States Environmental Protection Agency and the California Air Resources Board. Any part or parts replaced under this warranty shall become the property of **Moto Guzzi**.

In the State of California only, emission related warranted parts are explicitly defined by the state's Emissions Warranty Parts List. These warranted parts are: carburetor and internal parts; intake manifold; fuel tank; fuel injection system; spark advance mechanism; crankcase breather; air cutoff valves; fuel tank cap for evaporative emission controlled vehicles; oil filler cap; pressure control valve; fuel/vapor separator; canister; igniters; breaker governors; ignition coils; ignition wires; ignition points; condensers, and spark plugs if failure occurs prior to the first scheduled replacement; and hoses, clamps, fittings and tubing used directly in these parts. Since emission related parts may vary from model to model, certain models may not contain all of these parts and certain models may contain functionally equivalent parts.

In the state of California only, emergency repairs to the Emission Control System, as provided in the applicable state Administrative Code, may be performed by NON-authorized **Aprilia** dealers. An emergency situation exists when an **Aprilia** dealer is not reasonably available, a part is not available within 30 days, or a repair is not completed within 30 days. Any replacement part can be used in an emergency repair. **Moto Guzzi** will

reimburse the owner for the expenses, including diagnosis, not to exceed **Moto Guzzi's** suggested retail price for all warranted parts replaced and labor charges based on **Moto Guzzi's** recommended time allowance for the warranty repair and the geographically appropriate hourly labor rate. The owner may be required to keep receipts and failed parts in order to receive compensation.

## II - LIMITATIONS

This Emission Control System warranty shall **NOT** cover any of the following:

**A)** Repair or replacement required as a result of

- 1 . accident,
- 2 . misuse,
- 3 . repairs improperly performed or replacements improperly installed,
- 4 . use of replacement parts or accessories not conforming to **Moto Guzzi** specifications which adversely affect performance, and/or
- 5 . use in competitive racing or related events.

**B)** Inspections, replacement of parts and other services and adjustments required for maintenance.

**C)** Any motorcycle on which the odometer mileage has been changed so that actual mileage cannot be readily determined.

### III - LIMITED LIABILITY

**A.** The liability of **Moto Guzzi** under this Emission Control System Warranty is limited solely to the remedying of defects in material or workmanship by an authorized **Moto Guzzi** motorcycle dealer at its place of business during customary business hours. This warranty does not cover inconvenience or loss of use of the motorcycle or transportation of the motorcycle to or from the **Moto Guzzi** dealer.

**Moto Guzzi** SHALL NOT BE LIABLE FOR ANY OTHER EXPENSES, LOSS OR DAMAGE, WHETHER DIRECT, INCIDENTAL, CONSEQUENTIAL OR EXEMPLARY ARISING IN CONNECTION WITH THE SALE OR USE OF OR INABILITY TO USE THE **Moto Guzzi** MOTORCYCLE FOR ANY PURPOSE. SOME STATES DO NOT ALLOW THE EXCLUSION OR LIMITATION OF ANY INCIDENTAL OR CONSEQUENTIAL DAMAGES, SO THE ABOVE LIMITATIONS MAY NOT APPLY TO YOU.

**B.** NO EXPRESS EMISSION CONTROL SYSTEM WARRANTY IS GIVEN BY **Moto Guzzi** EXCEPT AS EXPLICITLY SET FORTH HEREIN. ANY EMISSION CONTROL SYSTEM WARRANTY IMPLIED BY LAW, INCLUDING ANY WARRANTY OF MERCHANTABILITY OR FITNESS FOR A PARTICULAR PURPOSE, IS LIMITED TO THE EXPRESS EMISSION CONTROL SYSTEM WARRANTY TERMS STATED IN THIS WARRANTY. THE FOREGOING

STATEMENTS OF WARRANTY ARE EXCLUSIVE AND IN LIEU OF ALL OTHER REMEDIES. SOME STATES DO NOT ALLOW LIMITATIONS ON HOW LONG AN IMPLIED WARRANTY LASTS, SO THE ABOVE LIMITATIONS MAY NOT APPLY TO YOU.

**C.** No dealer is authorized to modify this **Moto Guzzi** Limited Emission Control System Warranty.

**D.** **Moto Guzzi** shall be liable for damages to other vehicle components proximately caused by a failure under warranty of any warranted part.

**E.** Any add-on or modified part exempted by the Air Resources Board from the prohibitions of Vehicle Code section 27156 may be used on a vehicle or engine. Such use, in and of itself, shall not be grounds for disallowing a warranty claim made in accordance with this article. **Moto Guzzi** shall not be liable under this article to warrant failures of warranted parts caused by the use of an add-on or modified part.

**F.** Except as provided in subsection (1) above, any adjustment of a component which as a factory installed, and properly operating, adjustment limiting device (such as an idle limiter cap) is eligible for warranty coverage under subsection (d) or (i).

### IV - LEGAL RIGHTS

THIS WARRANTY GIVES YOU SPECIFIC LEGAL RIGHTS, AND YOU MAY ALSO

HAVE OTHER RIGHTS WHICH VARY FROM STATE TO STATE.

### V - THIS WARRANTY IS IN ADDITION TO THE LIMITED WARRANTY

THIS WARRANTY IS IN ADDITION TO THE **Moto Guzzi** LIMITED MOTORCYCLE WARRANTY.

### VI-ADDITIONAL INFORMATION

Any replacement part that is equivalent in performance and durability may be used in the performance of any maintenance or repairs. However, **Moto Guzzi** is not liable for these parts. The owner is responsible for the performance of all required maintenance. Such maintenance may be performed at a service establishment or by any individual.

The warranty period begins on the date the motorcycle is delivered to an ultimate purchaser.

### Piaggio & C. S.p.A.

Viale Rinaldo Piaggio, 25

56025 Pontedera (PI) Italy

Telephone: 0039-0587-272111

Fax: 0039-0587-272040

### Piaggio Group Americas, Inc.

860 Washington Street, 9th Floor

New York, NY 10014

## 1 General mandatory requirements

U.S.A.

Phone: (212) 380 4400

Fax: 310-604-3989

email: [customercare@us.piaggio.com](mailto:customercare@us.piaggio.com)

# V100 Mandello - V100 Mandello S



**CHAPTER 02**  
**Vehicle**

## Main components distribution



2 Vehicle

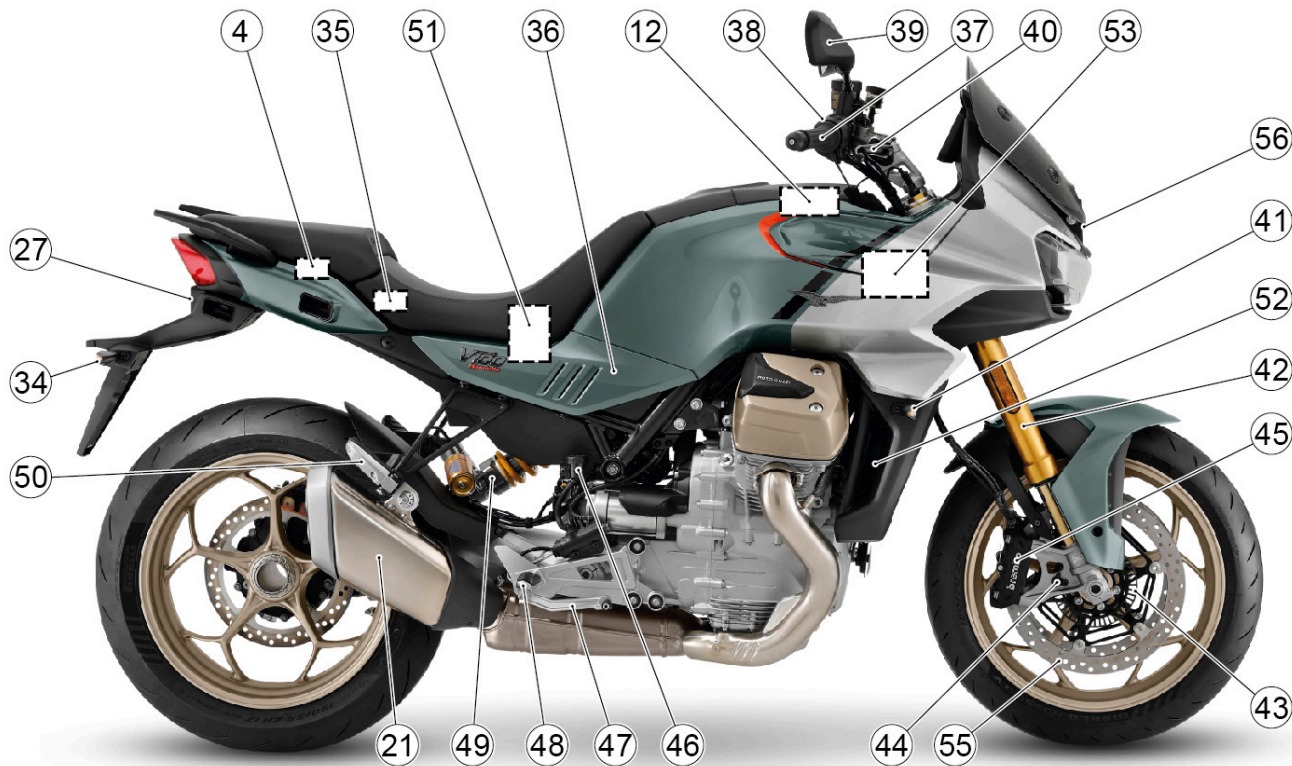

**Key for location of main components**

- 1 . Headlamp
- 2 . Adjustable windshield

- 3 . Front left turn indicator
- 4 . USB port
- 5 . USB socket (if applicable)
- 6 . Instrument panel

- 7 . Clutch lever
- 8 . Left rear-view mirror
- 9 . Left light switch
- 10 . Fuel tank cap

- 11 . Fuel tank
- 12 . Air filter
- 13 . Left side fairing
- 14 . Main fuses
- 15 . Rider saddle
- 16 . Passenger saddle
- 17 . Rear light
- 18 . Seat lock
- 19 . Number plate light
- 20 . Rear left turn indicator
- 21 . Silencer
- 22 . Rear brake calliper
- 23 . Passenger left footrest
- 24 . Side stand
- 25 . Left rider footrest
- 26 . Gear shift lever

## **Instrument cluster**

- 27 . Rear radar (where required)
- 28 . Engine oil filler cap/dipstick
- 29 . Horn
- 30 . Front left brake calliper
- 31 . Left hand front brake disc
- 32 . Left fork stem
- 33 . Front mudguard
- 34 . Rear right turn indicator
- 35 . Secondary fuses
- 36 . Right side fairing
- 37 . Throttle control
- 38 . Right light switch
- 39 . Right rear-view mirror
- 40 . Front brake lever
- 41 . Front right turn indicator

- 42 . RH fork stanchion
- 43 . Front tone wheel
- 44 . Front tone wheel sensor
- 45 . Front right brake calliper
- 46 . Rear brake oil tank
- 47 . Rear brake lever
- 48 . Right rider footrest
- 49 . Rear shock absorber (adjustable)
- 50 . Right passenger footrest
- 51 . Battery
- 52 . Radiator
- 53 . Radiator expansion tank
- 54 . Rear brake disc
- 55 . Right hand front brake disc
- 56 . Front radar (where required)



### Instrument cluster - Key

- |   |  |   |
|---|--|---|
| <p>1 . Audible warning device;</p> <p>2 . Turn indicator control;</p> <p>3 . Up button (MODE UP);</p> <p>4 . Set button (MODE SET);</p> | <p>5 . Right button (MODE RIGHT);</p> <p>6 . Down button (MODE DOWN);</p> <p>7 . Low beam / high beam / flash high beam switch;</p> <p>8 . Cruise control selector;</p> <p>9 . Riding mode button;</p> | <p>10 . Engine start / stop switch;</p> <p>11 . Daytime running lights (DRL) / night lights / additional headlights switch (if applicable);</p> <p>12 . Instrument panel and indicators;</p> <p>13 . Ignition switch / steering lock;</p> |
|---|--|---|

- 14 . Clutch lever;
- 15 . Front brake lever;
- 16 . Throttle grip;
- 17 . USB socket (if provided).

## Digital instrument panel

### Key:

- 1 . Multifunctional digital display box.
- 2 . Indicator lights.



The dashboard has an immobilizer system which prevents start-up in case the system does not identify a key which has been stored before.

The vehicle is delivered to the customer with two pre-programmed keys. The dashboard accepts a maximum of four keys at the same time: contact an Official **Moto Guzzi** Dealer to enable these keys or to disable a key that has been lost. Upon vehicle delivery, approximately ten seconds after the key is set to ON, the instrument cluster requests a personal five-digit code to be entered.

See the chapter "**Advanced functions**" for instructions on modifying the personal code

In case of code entry request, a box with variable values from 0 to 9 will be shown on the display using the MODE navigation buttons. Confirm the selection with a short press of the MODE SET button until completing the five digits; once all digits are entered, complete the operation by turning the ignition key to the OFF position.

**It is important to remember the personal code because:**

- the vehicle can be started if the immobilizer system is faulty
- the instrument cluster need not be replaced should the ignition switch be changed
- new keys can be programmed



### N.B.:



**IF THE PERSONA CODE IS NOT MEMORISED AND THE VEHICLE IS USED, THE MESSAGE DISAPPEARS AFTER 10 SECONDS**

**BUT REAPPEARS WITH EACH KEY ON.**

### N.B.:



**THE FACTORY SET CODE IS COMPOSED OF FIVE ZEROES.**

## Indicator light unit

### Key:

- 1 . MI warning light, orange;
- 2 . High beam indicator lamp, blue;
- 3 . Cruise control indicator lamp, green;
- 4 . ABS indicator light, orange;
- 5 . Left turn indicator warning light, green;
- 6 . Right turn indicator warning light, green;
- 7 . MGCT warning light, orange;
- 8 . DRL indicator lamp, green;
- 9 . Low fuel indicator light, orange;
- 10 . Neutral indicator light, green;
- 11 . Immobilizer / over-revs indicator lamp, red.



## Digital display

N.B.:



**THE INSTRUMENT CLUSTER IS EQUIPPED WITH A TWILIGHT SENSOR**

**THANKS TO WHICH, BASED ON THE AMBIENT LIGHTING, CAN SWITCH FROM DAY TO NIGHT MODE.**

**IF THE "HEADLAMP MODE" FUNCTION (SEE SECTION "ADVANCED FUNCTIONS" ) IS SET TO THE "AUTO" STATUS, THE TWILIGHT SENSOR WILL SWITCH THE HEADLIGHT FROM D.R.L. TO LOW BEAM AND VICE-VERSA.**

- Turning the ignition switch to 'KEY ON', the following illuminate on the dashboard for about two seconds:
    - A dynamic graphic presentation.
    - All indicator lights.
- (where available)**

If the **GUZZI MIA** ECU is present, pressing and holding the "MODE RIGHT" button accesses navigation mode.

Pressing and holding the button changes the digital display mode from **ROAD** to **NAVI**, and then to **MENU**.

Pressing and holding the MODE RIGHT button again scrolls through the "modes" available.



The following information is displayed in **ROAD** mode:

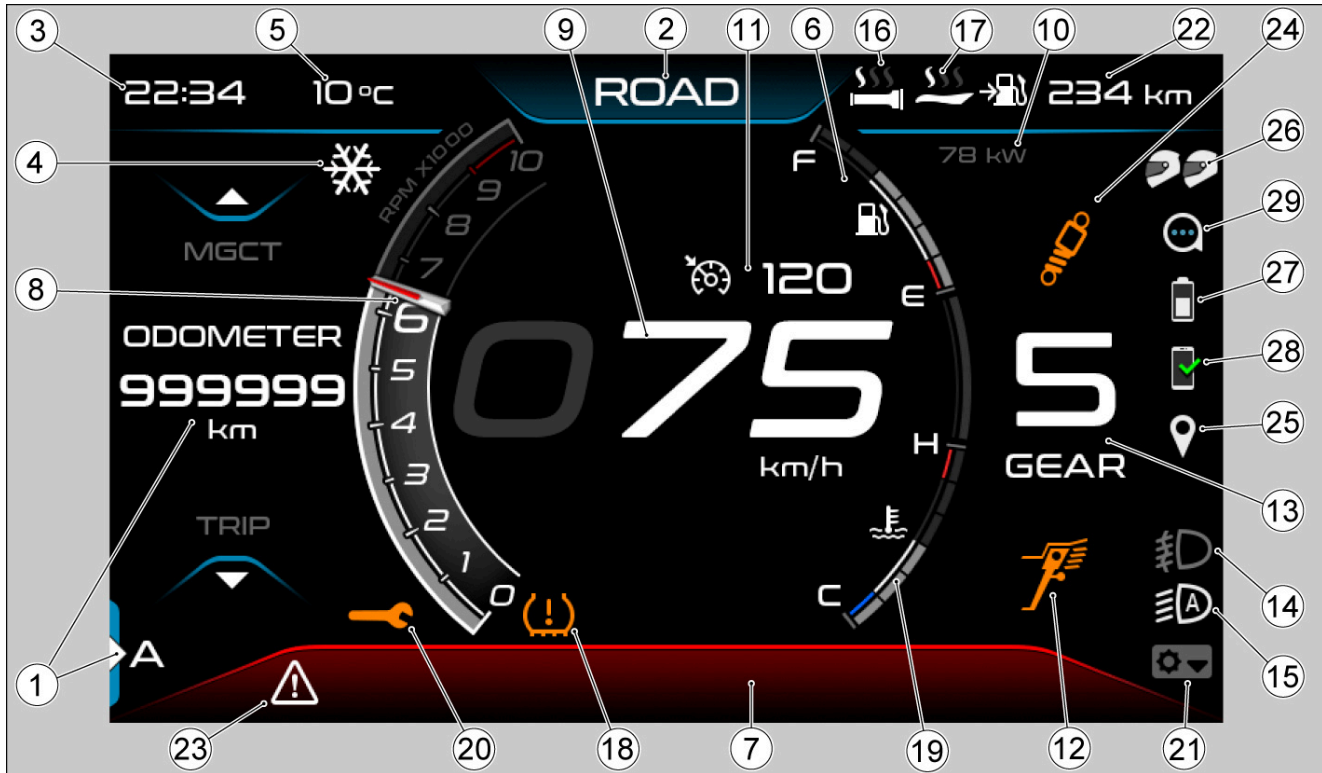

### ROAD screen legend

1) On-board computer log (TRIP LOG A / TRIP LOG B). (Where the Guzzi Mia control unit is present: telephone, music, media player. (Where the components are

present): tyre pressure, heated handgrips, heated seat;

2) Riding mode active;

3) Clock (displayed in 24 or 12 hour mode, without the AM / PM indication);

4) Ice hazard icon (displayed at temperatures from -15 °C (5 °F) a +3 °C (37.4 °F)) / Battery warning indicator (voltage between poles too low) (both visible when alert conditions arise);

5) Ambient temperature (shown in °C or °F);

- 6) Fuel gauge;
- 7) Information pop-up area;
- 8) Engine speed (rpm x 1000);
- 9) Speed (speedometer) (displayed in km/h or in mph);
- 10) Reduced map indication (if applicable);
- 11) Cruise control speed (when the system is active, indicates the set cruise speed);
- 12) Open side stand indicator;
- 13) Gear selected;
- 14) Automatic lights mode active;
- 15) Fog lights active (if applicable);
- 16) Hand grip heating level indicator;
- 17) Seat heating level indicator;
- 18) Low tyre pressure alarm (displayed where applicable);
- 19) Water temperature value (displayed in °C or °F);
- 20) Service icon;
- 21) Downshift status (displayed where implemented);
- 22) Driving in reserve (only when the reserve indicator is on) (displayed in km or mi);
- 23) General warning icon;
- 24) Suspension failure icon (V100 Mandello S)

### Where the Guzzi Mia control unit is present:

- 25) GPS/Navigator (where active);
- 26) Rider/passenger intercom;
- 27) Battery level indicator relative to connected smartphone;
- 28) Audio transmission with smartphone for calling, sending vocal commands and playing music;
- 29) Data link with smartphone;

### Warnings

#### MAINTENANCE MESSAGE

When the maintenance time thresholds are exceeded, the icon depicting a wrench will appear, indicating the need to carry out scheduled maintenance on the vehicle.

This message can be reset once the scheduled maintenance has been completed by an **authorised Moto Guzzi Dealer or service centre**.

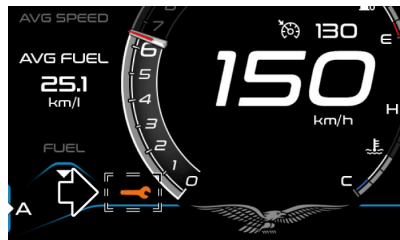

#### ICE HAZARD WARNING

At external temperatures between -15 °C (5 °F) and 3 °C (37.4 °F), the ice hazard symbol appears on the display.

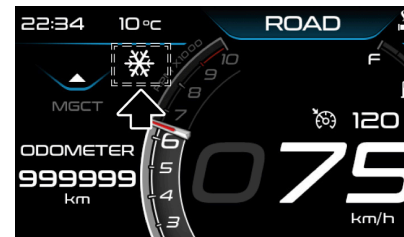

#### LOW BATTERY WARNING

The lighting of the battery symbol indicates a problem in the battery charging system.

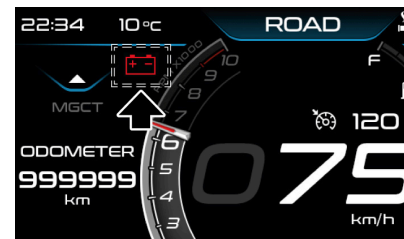

#### OVERTEMPERATURE WARNING

When the coolant temperature is 115 °F (239 °C) or higher: the temperature icon turns red and flashes together with the coolant temperature gauge.

**WARNING**

**STOP THE VEHICLE AND WAIT FOR THE ENGINE TO COOL.**

**WARNING**

**IN ORDER TO PROTECT THE ENGINE, THE ELECTRONIC CONTROL UNIT HAS A STRATEGY WHICH, IF THE COOLANT TEMPERATURE IS PARTICULARLY HIGH, COULD LEAD TO THE ENGINE SHUTTING DOWN AFTER A LONG PERIOD WITH THE VEHICLE STATIONARY AND THE GEARBOX IN NEUTRAL. THIS STRATEGY, FOR SAFETY REASONS, WILL NEVER BE ACTIVATED IF THE**

**VEHICLE IS IN MOTION OR IF THE GEARBOX IS NOT IN NEUTRAL.**

**FUEL LEVEL**

The tank fuel level gauge is represented on the display by a number of bars.

When only the first bar remains on, it will change colour to orange, as does the symbol on the digital display. At the same time, the dedicated indicator light on the instrument panel comes on.

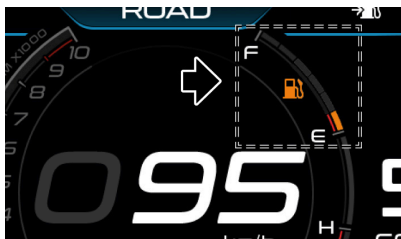
**WARNING**

**IF THE RESERVE FUEL WARNING LAMP FLASHES AT KEY-ON, THIS INDICATES THAT THE FUEL LEVEL SENSOR IS DISCONNECTED.**

**IF THE FUEL SENSORS DO NOT WORK CORRECTLY, THE BARS MAY NOT BE DISPLAYED CORRECTLY.**

**THEREFORE CONTACT AN Official Moto Guzzi Dealer.**

**N.B.:**

**THE FUEL LEVEL INDICATION CAN CHANGE DEPENDING ON THE INCLINATION OF THE MOTORCYCLE, FROM WHEN IT IS POSITIONED ON THE SIDE STAND OR DRIVING ON LONG SLOPES OR LONG DESCENTS.**

**FUEL RANGE**

Indicates the remaining range that can be covered with the petrol in the tank (displayed in km or mi).



When the vehicle goes into reserve, the remaining range disappears, two dashes (-) will be displayed in its place, and "TRIP FUEL" will appear in the trip log, which counts the distance travelled in reserve. This value is reset every time the gasoline

level in the tank exceeds the reserve threshold.



### IMMOBILIZER

With the key in the "KEY OFF" position, the immobilizer indicator light flashes to indicate the activation of the system. To reduce battery consumption the light stops flashing after about 48 hours.

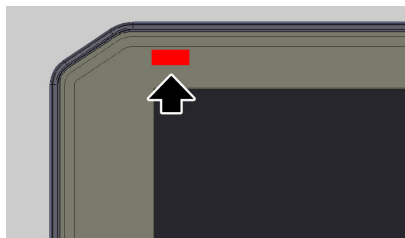

### RIDING MODE SETTING SCREEN

The riding mode setting screen can be accessed from the main screen of the display, by pressing and holding the "RIDING MODE" button on the right hand handlebar control set.

See the paragraph "MGCT system" for instructions on modifying parameters.

Press "RIDING MODE" or "MODE SET" briefly to exit the setting mode screen.

	SPORT	ROAD	TOUR	RAIN
MGCM	1	2	1	2
MGCT	2	1	OFF	4
MGCA	ON 30 km/h	OFF	ON	ON -- km/h
MGCS	M1	M2	A2	A1

MODIFY → MOVE ↓ RESET ■ EXIT □

### Alarms

In the event of a fault, the Pop-up area of the digital display will turn red and a different message will be displayed depending on the cause.

Take your vehicle to an **Official Moto Guzzi Dealer** as soon as possible.

#### SERVICE ALARM

If there is a fault on the instrument panel or from the ECU, the instrument panel signals the fault by displaying the message "ALARM SERVICE" along with the general alarm icon.

If there is an immobilizer failure at ignition, the instrument cluster requests you to enter a user code. If the code is entered correctly, the dashboard signals the failure by displaying the message "ALARM SERVICE" along with the general alarm icon.



### URGENT SERVICE ALARM

The serious anomaly is signalled by the rapid flashing (two flashes per second) of the message "URGENT SERVICE" accompanied by the general alarm icon in the Pop-up area which will turn red. Take your vehicle to an **Official Moto Guzzi Dealer** as soon as possible. In these cases the ECU activates a safety procedure limiting vehicle performance in order to allow the rider to go to an **Official Moto Guzzi Dealer** at a reduced speed.

Depending on the type of failure, performance can be limited in three ways: a) by reducing the maximum torque produced; b) by keeping the engine at idle speed but slightly accelerated (during this operation, the throttle control is disabled); c) the engine rpm is steady at around 3000 rpm; Under these conditions the throttle control provides limited management of the torque.

**N.B.:**



THE PRESENCE OF THE "URGENT SERVICE" ERROR ON THE DIGITAL DISPLAY AND ACCOMPANIED BY THE FLASHING OF THE FOUR ARROWS TO WARN THE VEHICLES FOLLOWING OF A POSSIBLE DANGEROUS SITUATION, UNTIL THE TURN INDICATOR IS ACTIVATED TO ALLOW THE DRIVER TO PULL OVER .



#### ENGINE OIL FAULT

In the event that an oil pressure anomaly is detected, the digital display will show the message "ALARM OIL PRESSURE" accompanied by the general alarm icon, all flashing in the Pop-up area which will turn red.

#### WARNING



**STOP THE VEHICLE AND CONTACT AN Approved Moto Guzzi dealer AS SOON AS POSSIBLE.**



In the event that an oil pressure sensor anomaly is detected, the digital display will show the message "ALARM OIL SENSOR" accompanied by the fixed general alarm icon, in the Pop-up area which will turn red.

#### WARNING



**TAKE YOUR VEHICLE TO AN Official Moto Guzzi Dealer AS SOON AS POSSIBLE.**



#### MGCT DISABLED ALARM

The MGCT system disabling alarm is activated when there is a problem that can cause the system itself to be disabled.

#### WARNING



**DRIVE CAREFULLY AND CONTACT AN Official Moto Guzzi Dealer AS SOON AS POSSIBLE.**



#### IMMOBILIZER ALARMS

For immobilizer alarms, refer the specific paragraph "Immobilizer system operation". The error code may vary.

If there is an alarm, the user code must be entered to start the vehicle.

#### WARNING



THE DISPLAY WILL SHOW THE ALARM MESSAGE, ACCOMPANIED BY THE GENERAL WARNING LIGHT, IN THE POP-UP AREA WHICH WILL TURN RED.

**WARNING**



DRIVE CAREFULLY AND CONTACT AN Official Moto Guzzi Dealer AS SOON AS POSSIBLE.



**ELECTRONIC CONTROL UNIT DISCONNECTED ALARM**

If a lack of connection of the E.C.U. is detected, the instrument panel will signal the anomaly by displaying the message "ALARM CAN ECU DISCONNECTED" accompanied by the general alarm warning light in the Pop-up area which will turn red.

**N.B.:**



THE MESSAGE "ALARM CAN ECU DISCONNECTED" REMAINS ON THE DIGITAL DISPLAY AND THE HAZARD WARNING LIGHTS WILL CONTINUE TO FLASH (TO WARN OTHER ROAD USERS BEHIND THE VEHICLE OF POTENTIAL DANGER) UNTIL THE RIDER ACTIVATES THE RIGHT HAND TURN SIGNAL TO INDICATE THAT THEY ARE ABOUT TO PULL OVER AND STOP.



**"CAN BUS OFF" ELECTRONIC CONTROL UNIT DISCONNECTED ALARM**

If a lack of connection with the CAN line is detected, the display will show the alarm message "ALARM CAN BUS OFF" accompanied by the general warning icon in the Pop-up area which will turn red.

**WARNING**



DRIVE CAREFULLY AND CONTACT AN Official Moto Guzzi Dealer AS SOON AS POSSIBLE.



**HEADLAMP DISCONNECTED ALARM "CAN HLU"**

If a lack of connection between the instrument panel and the headlight is detected, the display will show the alarm message "ALARM CAN HLU" accompanied by the general warning icon in the Pop-up area which will turn red.

**N.B.:**



THE FRONT TURN INDICATORS ALSO FLASH WHILE THE ERROR "ALARM

**CAN HLU" IS ACTIVE ON THE DIGITAL DISPLAY.**

## WARNING



**DRIVE CAREFULLY AND CONTACT AN Official Moto Guzzi Dealer AS SOON AS POSSIBLE.**



## BRAKES STUCK ALARM

In the event that constant pressure is maintained on at least one of the brake levers, with the vehicle moving at a speed equal to or greater than 10 Km/h (6 mph):

the display will show the alarm message "WARNING BRAKE STUCK" accompanied by the general warning icon and the Pop-up area will turn orange.



If the pressure is maintained for more than 60 seconds, with the vehicle moving at a speed equal to or greater than 10 Km/h (6 mph):

the display will show the alarm message "ALARM BRAKE STUCK" accompanied by the general warning icon and the Pop-up area will turn red.



## CAUTION



**IF THE ALARM MESSAGE DOES NOT DISAPPEAR WHEN RELEASING THE BRAKE LEVERS, STOP THE VEHICLE**

**AND CONTACT AN Official Moto Guzzi Dealer FOR DIAGNOSIS AND TROUBLESHOOTING OF THE BRAKE SYSTEM.**

## mapping selection

The engine control unit has 4 different selectable "riding modes" for managing the electronic accelerator, displayed as follows in the upper central part of the digital display:

- SPORT
- ROAD
- TOUR
- RAIN



The **SPORT** mode is designed for a more dynamic use of the vehicle. The throttle response is rapid, engine braking and traction control are minimally invasive.

The **ROAD** mode is designed for urban use. Engine response is less aggressive and engine braking is more invasive than in SPORT mode, while traction control is set to the intermediate level.

The **TOUR** mode is designed for a touristic use of the vehicle. The engine response is less aggressive, the engine brake and traction control are set to the intermediate level.

The **RAIN** mode is intended for use on surfaces with poor traction. The engine response is mild, the engine brake is efficient and the traction control is set to the maximum level.

All of the "riding modes" listed above can be configured by the user, as shown in the "ADVANCED FUNCTIONS" section.

To cycle through the different riding modes, press the button shown in the figure on the right hand handlebar control set briefly.

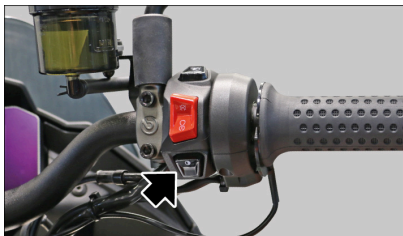

**N.B.:**



**DIFFERENT RIDING MODES MAY ALSO BE SELECTED ON THE FLY WHILE THE VEHICLE IS MOVING,**

**PROVIDED THAT THE THROTTLE GRIP IS RELEASED.**

**RIDING MODES MAY ALSO BE PRESELECTED WHILE THE THROTTLE IS OPEN. IN THIS CASE, THE NEW MODE IS ONLY EFFECTIVELY IMPLEMENTED WHEN THE THROTTLE IS CLOSED AGAIN. IN THIS CASE THE ICON AND THE NAME OF THE RIDING MODE WILL FLASH.**



**N.B.:**



**IF THE THROTTLE IS OPENED WHILE THE NEW RIDING MODE IS SHOWN IN FLASHING MODE ON THE DISPLAY (I.E. MODE IS PRESELECTED ONLY AND PENDING IMPLEMENTATION BY THE ECU), THE PRESELECTED NEW RIDING MODE WILL NOT BE EFFECTIVELY IMPLEMENTED UNTIL THE THROTTLE GRIP IS RELEASED.**

**IF A NEW RIDING MODE IS SELECTED WHILE THE THROTTLE IS OPEN, THE NEW RIDING MODE REQUESTED WILL BE SHOWN IN FLASHING MODE UNTIL THE THROTTLE GRIP IS RELEASED.**

**N.B.:**



**IF THE REQUESTED RIDING MODE CONTINUES TO BE DISPLAYED IN FLASHING MODE, THIS MEANS THAT NOT ALL THE CONDITIONS NECESSARY FOR IMPLEMENTATION OF A NEW MODE ARE MET, E.G.: THROTTLE OPEN, CLUTCH LEVER IN USE ETC.**

To gain access to the riding mode settings screen, press and hold the relative button on the right hand lights switch.

Using the "MODE UP" or "MODE DOWN" buttons, the desired parameter may be selected and by briefly pressing the "MODE RIGHT" button, the intervention value can be increased.

Once the maximum level is reached, the setting will restart from the minimum intervention value.

After setting the parameters as desired, press "MODE SET" briefly to exit the screen.

Press and hold "MODE SET" to restore the factory settings.

**N.B.:**



**THE MGCS ITEM IS ONLY PRESENT ON V100 MANDELLO S.**

	SPORT	ROAD	TOUR	RAIN
MGCM	1	2	1	2
MGCT	2	1	OFF	4
MGCA	ON 30 km/h	OFF	ON	ON - km/h
MGCS	M1	M2	A2	A1
	MODIFY ▶	MOVE ◀	RESET ■	EXIT ◻

## Electronic controls of the vehicle

Moto Guzzi V100 is equipped with an advanced integrated electronic control system that helps improving the performance and the rider's safety.

The system consists of:

**MGCM:** Moto Guzzi Engine Control;

**MGCT:** Moto Guzzi Traction Control;

**MGCA:** Moto Guzzi Aerodynamic Control;

**MGCS:** Moto Guzzi Suspension Control (where required);

**MGQS:** Moto Guzzi Quick Shift (if applicable);

**TPMS:** Tire Pressure Measurement System (if applicable) - (see "Tires" section).

### MGCM - Moto Guzzi Engine Control

Moto Guzzi Engine Control is the system that controls engine power delivery:

- Level 1 has an aggressive delivery and is suitable for performance use and expert riders.
- Level 3 has a gentle and progressive delivery of power and is recommended for use in poor grip / wet conditions. The vehicle is more easily handled.

### ABS

The ABS with CORNERING is a device to avoid the wheels locking in case of emergency braking also when cornering, thus increasing vehicle stability when braking when compared with a traditional braking system.

The CORNERING mode takes into account the motorcycle's lean angle, so as to maximise efficiency without endangering the rider.

The ABS system improves vehicle control provided that the physical limits of vehicle grip on the road are not exceeded. The rider is fully responsible for riding at a suitable speed based on weather and road conditions, always leaving an appropriate safety margin.

Under no circumstances can the ABS system compensate for the rider's misjudgement or improper use of brakes.

**N.B.:**



**WHEN THE ABS STARTS WORKING, A PULSING IS FELT ON THE BRAKE LEVER.**

### CAUTION



**THE ANTI-LOCK BRAKING SYSTEM OF THE WHEEL DOES NOT PREVENT FALLS WHILE CORNERING.**

**AN EMERGENCY BRAKING WITH THE VEHICLE INCLINED, HANDLEBAR TURNED, ON UNEVEN OR SLIPPERY ROADS, OR WITH POOR GRIP, CREATES A LACK OF STABILITY DIFFICULT TO HANDLE. RIDE CAREFULLY AND SENSIBLY AND ALWAYS BRAKE GRADUALLY.**

**DO NOT SPEED RECKLESSLY. THE VEHICLE GRIP ON THE ROAD IS SUBJECT TO LAWS OF PHYSICS WHICH NOT EVEN THE ABS SYSTEM CAN ELIMINATE.**

When the vehicle is started, after the initial instrument panel check cycle, the ABS warning lamp flashes until the vehicle reaches a speed of 3.1 mph (5 km/h), after which it goes out.



If the ABS warning lamp lights steadily or continues to flash even after exceeding a speed of 5 km/h (3.1 mph), this means that a fault has been detected and that the ABS system has been disabled.

In this case carry out the following operations:

- stop the vehicle;
- OFF-ON key;
- ride over 5 km/h (3.1 mph): the ABS warning light must be turned off;
- ABS is functioning.

If the ABS disabled indication remains:

**N.B.:**



**IF THIS OCCURS, CONTACT AN OFFICIAL Moto Guzzi dealer.**

**CAUTION**



**IF THE ABS WARNING LIGHT FLASHES MORE FREQUENTLY THAN THAT OF THE INITIAL CHECK, IT MEANS THAT THERE IS A PROBLEM WITH THE IMU INERTIAL PLATFORM, WHICH WILL NOT PROVIDE INFORMATION TO ANY OF THE VEHICLE CONTROL SYSTEMS.**

**IN THIS CASE THE MGCT TRACTION CONTROL IS DEACTIVATED, THEREFORE RIDING THE VEHICLE WILL BE EXTREMELY DANGEROUS. DRIVE WITH THE MAXIMUM CAUTION AND CONTACT AN official Moto Guzzi Dealer.**

**N.B.:**



**IN THE EVENT OF A PROLONGED ROTATION OF THE REAR WHEEL WITH THE FRONT WHEEL LOCKED (BURNOUT, MOTORCYCLE PLACED ON THE CENTRAL STAND, ETC.) THE SYSTEM CAN BE AUTOMATICALLY DEACTIVATED WHEN THE ABS AND**

**THE MGCT ABD ABS INDICATORS ARE SWITCHED ON STEADY. TO REACTIVATE, TURN THE IGNITION SWITCH OFF AND THEN ON AGAIN AND SELECT THE REQUIRED SETTING.**

**CAUTION**



**THE SAFETY PROVIDED BY THE ABS DOES NOT, IN ANY CASE, JUSTIFY RISKY MANOEUVRES. EVEN THOUGH THE ABS SYSTEM ENSURES GREATER VEHICLE CONTROL IN THE EVENT OF EMERGENCY BRAKING, ALWAYS OBSERVE THE CORRECT MINIMUM SAFETY DISTANCE FROM THE VEHICLE IN FRONT OF YOU.**

**CAUTION**



**THE ABS SYSTEM USES SIGNALS RECEIVED FROM THE TWO TONE WHEELS (FRONT AND REAR) TO CONTROL THE PRESSURE APPLIED TO BOTH BRAKES. IT IS IMPORTANT TO ALWAYS CHECK THAT THE TONE WHEEL IS IN PERFECT CONDITION, AND PERIODICALLY CHECK THAT THE DISTANCE FROM THE SENSOR**

**IS CONSTANT OVER THE ENTIRE 360 DEGREES.**

**WHEN REMOVING AND REFITTING THE FRONT WHEEL, IT IS VERY IMPORTANT TO ENSURE THAT THE GAP BETWEEN THE TONE WHEEL AND THE SENSOR AND THE PARALLEL ALIGNMENT BETWEEN THE TWO COMPONENTS ARE AS SPECIFIED. FOR CHECKING AND ADJUSTMENT, CONTACT AN Authorised Moto Guzzi Garage.**

#### CAUTION



**WHERE THE MOTORCYCLE HAS AN ABS SYSTEM, NON-APPROVED BRAKE PADS AND TYRES COMPROMISE SMOOTH BRAKING, DRASTICALLY REDUCING DRIVING SAFETY.**

**N.B.:**



**HAVING A SIGNIFICANT ACCURACY OF READING THE TONE WHEELS, THE SYSTEM'S SENSORS MAY GENERATE AN INDICATION OF SPEED OF SOME km/h (mi) ON THE DIGITAL DISPLAY WHEN THE MOTORCYCLE**

**IS STOPPED AND THE ENGINE IS RUNNING.**

**SUCH BEHAVIOUR IS TO BE CONSIDERED NORMAL AND DOES NOT CREATE MALFUNCTIONS IN THE SYSTEM.**

#### MGCT - Moto Guzzi Traction Control

##### Traction control:

is a system developed to control the relative skidding of the wheels and help the rider to have greater control and safety of the vehicle.

The MGCT system also intervenes in an optimal manner during cornering, thus controlling skidding in this stage of the ride.

This is made possible by the inertia sensor platform, which provides the ECU with precise information concerning the inclination of the motorcycle.

##### MGCT SYSTEM DEACTIVATED MANUALLY

At key-on and after the initial dashboard check cycle, if the system is deactivated, the MGCT indicator light remains lit and fixed until the rider activates the system again.

##### MGCT SYSTEM ACTIVE

At key-on and after the initial instrument cluster check cycle, the MGCT indicator light flashes slowly if the system has remained active since the previous use. The light will turn off once 3.1 mph (5 km/h) is exceeded.

If the MGCT indicator light is on permanently it means that a malfunction was detected and the traction control is automatically deactivated. At the same time as the indicator light comes on, the message "MGCT DISABLED" will be shown in the Pop-up area of the display.

In this case carry out the following operations:

- stop the vehicle;
- OFF-ON key;
- reactivate the system manually;
- ride over 5 km/h (3.1 mph): the MGCT indicator light must turn off;
- MGCT is working.

If the MGCT disabled message remains:

**N.B.:**



**IF THIS OCCURS, CONTACT AN OFFICIAL Moto Guzzi dealer.**

#### WARNING



**THE MGCT SYSTEM ACTS ON THE REAR WHEEL ON THE BASIS OF INFORMATION RECEIVED FROM TONE WHEELS INSTALLED ON BOTH WHEELS. IT IS IMPORTANT TO**

**ALWAYS CHECK THAT THE TONE WHEEL IS IN PERFECT CONDITION, AND PERIODICALLY CHECK THAT THE DISTANCE FROM THE SENSOR IS CONSTANT OVER THE ENTIRE 360 DEGREES. WHEN REMOVING AND REFITTING THE FRONT WHEEL, IT IS VERY IMPORTANT TO ENSURE THAT THE GAP BETWEEN THE TONE WHEEL AND THE SENSOR AND THE PARALLEL ALIGNMENT BETWEEN THE TWO COMPONENTS ARE AS SPECIFIED. FOR CHECKING AND ADJUSTMENT, CONTACT AN Authorised Moto Guzzi Garage.**

**N.B.:**



**IN THE EVENT OF A PROLONGED ROTATION OF THE REAR WHEEL WITH THE FRONT WHEEL LOCKED (BURNOUT, MOTORCYCLE PLACED ON THE CENTRAL STAND, ETC.) THE SYSTEM CAN BE AUTOMATICALLY DEACTIVATED WHEN THE ABS AND THE MGCT AND ABS INDICATORS ARE SWITCHED ON STEADY. TO REACTIVATE, TURN THE IGNITION SWITCH OFF AND THEN ON AGAIN AND SELECT THE REQUIRED SETTING.**

**N.B.:**



**HAVING A SIGNIFICANT ACCURACY OF READING THE TONE WHEELS, THE SYSTEM'S SENSORS MAY GENERATE AN INDICATION OF SPEED OF SOME km/h (mi) ON THE DIGITAL DISPLAY WHEN THE MOTORCYCLE IS STOPPED AND THE ENGINE IS RUNNING.**

**SUCH BEHAVIOUR IS TO BE CONSIDERED NORMAL AND DOES NOT CREATE MALFUNCTIONS IN THE SYSTEM.**

The system is active by default. However, if the system has been deactivated, in order to reactivate it, the user must access the specific screen using the selector button on the right hand handlebar control set.

Using the MODE navigation buttons, select level 1 if the level was set to 0.

If the MGCT system is activated when the vehicle is stationary, the relative indicator light will flash until 3.1 mph (5 km/h) is reached.

Press the MODE UP or MODE DOWN buttons briefly to increase or decrease the MGCT level setting from "1" (minimum system control) to "4" (maximum system control).

Using the MGCT/Cruise control command (if the cruise control is not active) it is

possible to modify the control value of the MGCT system directly from the main screen, in all riding modes.

The MGCT value is changed (from 1 to 4) with short up or down presses of the control.

From level 1, the MGCT is permanently disabled with a long press downwards.

To reset the MGCT, make a long or short push upwards.

**N.B.:**



**THIS IS ALSO POSSIBLE WITH THE MOTORCYCLE IN MOTION.**

**CAUTION**



**TO GAIN FAMILIARITY WITH THE MGCT SYSTEM, PREFERABLY USE LEVEL "4" TO START WITH, THEN TRY THE OTHER LEVELS TO IDENTIFY WHICH ARE THE BEST SUITED TO YOUR RIDING STYLE AND FOR DIFFERENT ROAD AND WEATHER CONDITIONS.**

**LEVEL '1' AND 'OFF' ARE SUITABLE FOR EXPERIENCED USERS.**

**THE OTHER LEVELS INCREASE THE INTERVENTION OF THE MGCT SYSTEM, UP TO THE MAXIMUM INTERVENTION OF LEVEL "4".**

To deactivate the system, set the control level to "OFF".

The MGCT warning light will be on steady.

#### CAUTION



**IF THE MGCT SYSTEM IS DEACTIVATED, A POP-UP WITH THE MESSAGE "MGCT DISABLED" IS SHOWN ON THE DIGITAL DISPLAY TO WARN THE RIDER THAT THERE IS NO TRACTION CONTROL ASSISTANCE.**

**THIS POP-UP CLEARS AFTER 5 SECONDS.**

**N.B.:**



**THIS IS ALSO POSSIBLE WITH THE MOTORCYCLE IN MOTION.**

**N.B.:**



**ONCE THE IGNITION SWITCH IS TURNED OFF, AT THE NEXT START UP THE MGCT SYSTEM MAINTAINS THE PREVIOUSLY SELECTED SETTINGS.**

#### **MGCA - Moto Guzzi Aerodynamic Control**

This system regulates the deployment of the aerodynamic deflectors on the tank and guarantees the protection of the rider from turbulence.

The system can be set to ON or OFF, or the vehicle speed at which the deflectors will deploy can be set to a range from 30 km/h to 80 km/h or from 20 mph to 50 mph.

The speed at which the deflectors are deployed can be adjusted by short presses of the MODE UP and MODE DOWN buttons.

This setting is individually selectable for each of the riding modes.

#### **MGCS - Moto Guzzi Suspension Control (where applicable)**

This vehicle is equipped with an ÖHLINS Smart EC 2.0. system.

The system is composed of front suspension, rear suspension and control unit (Suspension Control Unit).

MGCS provides preset damping levels, optimized for various conditions, both for the front and rear suspensions.

Through the control unit that receives signals from the various control units of the vehicle, the front and rear suspensions are constantly updated data on the driving conditions.

This results in an optimized compression and extension damping, based on the vehicle's behaviour during driving. The system permanently adjusts the compression and extension damping levels according to the circumstances.

Furthermore the spring pre-load of the front and rear suspension can be manually adjusted.

#### WARNING



**PAY SPECIFIC ATTENTION WHEN DISCONNECTING THE CONNECTORS, TO AVOID DAMAGING THEM, WHICH WOULD COMPROMISE THE OPERATION OF THE VEHICLE.**

There are two modes, Automatic and Manual:

- **A1 – Automatic dynamic** Mode specific for sportive road use.
- **A2 – Automatic comfort** Mode specific for road use aimed at comfort.

- **M1 – Manual dynamic** Mode specific for sportive road use.
- **M2 – Manual comfort** Mode specific for road use aimed at comfort.

For each mode, the control type of the MGCS system can be modified.

Depending on the selected mode, the following parameters can be modified:

- **Front firmness (front damping firmness):** Control that allows balancing the front suspension between comfort and stability. An adjustment aimed at comfort improves the filtering of the road bumps and the shock absorption; vice versa, an adjustment aimed at stability, increases the dampening of the movements.
- **Front compression damping:** Energy absorption control when the front suspension is compressed. Therefore, the compression is adjusted when the front wheel is subjected to a load.
- **Front rebound damping:** Energy absorption control when the front suspension is in extension phase. It adjusts the speed with which the suspension returns to the normal position after having been compressed.
- **Rear firmness (rear damping firmness):** Control that allows balancing the rear suspension between comfort and stability. An adjustment aimed at comfort improves the filtering of the road bumps and the shock absorption; vice versa, an adjustment

aimed at stability, increases the dampening of the movements.

- **Rear compression damping:** This function controls the energy absorbed by the rear shock absorber when it is compressed. Therefore, the compression speed is adjusted when the rear wheel is subjected to a load.
- **Rear rebound damping:** This function controls the energy absorbed by the rear shock absorber when it extends. It adjusts the speed with which the suspension returns to the normal position after having been compressed.
- **Brake support:** Energy absorption control when the vehicle is braking, based on the set resistance value, the load variation and consequently offering better control.

#### FACTORY SETTINGS

**Front firmness:** A1: 0 / A2: -5 / M1: - / M2: -

**Front compression:** A1: - / A2: - / M1: 28 / M2: 31

**Front rebound:** A1: - / A2: - / M1: 5 / M2: 20

**Rear firmness:** A1: 0 / A2: -5 / M1: - / M2: -

**Rear compression:** A1: - / A2: - / M1: 30 / M2: 31

**Rear rebound:** A1: - / A2: - / M1: 10 / M2: 15

**Brake support:** A1: 0 / A2: -5 / M1: - / M2: -

N.B.:



THE ADJUSTMENT RANGES OF THE REGISTERS VARY BETWEEN "AUTOMATIC" AND "MANUAL" AND ARE:

"AUTOMATIC": -5 (SOFT) / +5 (HARD)

"MANUAL": 1 (HARD) / 31 (SOFT)

(SOFT): THE HYDRAULIC BRAKE IS AT ITS MINIMUM VALUE. WHEN REFERRED TO THE COMPRESSION, THE SUSPENSION WILL BE SOFTER; WHEN REFERRING TO REBOUND, THE SUSPENSION RETURN WILL BE FASTER.

(HARD): THE HYDRAULIC BRAKE IS AT ITS MAXIMUM VALUE. WHEN REFERRED TO THE COMPRESSION, THE SUSPENSION WILL BE HARDER; WHEN REFERRING TO REBOUND, THE SUSPENSION RETURN WILL BE SLOWER.

#### CAUTION



IN CASE OF AN ELECTRICAL ANOMALY OR IF A SUSPENSION CONNECTOR IS DISCONNECTED, THE SUSPENSION ICON WILL FLASH ON THE DIGITAL DISPLAY TO INDICATE

**A MALFUNCTION OF THE MGCS SYSTEM.**

**THEREFORE, RIDE CAREFULLY AND IMMEDIATELY CONTACT AN official Moto Guzzi Dealer.**



**N.B.:**



**EVEN IF A FAULT IS SIGNALLED AND THEREFORE WHEN THERE IS NO ELECTRONIC SUSPENSION MANAGEMENT, THEY WILL NOT LOSE THEIR TRADITIONAL MECHANICAL FUNCTIONALITY.**

It uses the gear shift sensor signal on the gear lever to shift gears more quickly with a lower decrease in rpm than a traditional gear shift as regards upshifting.

The system is only active above an engine speed: of approximately 2500 rpm.

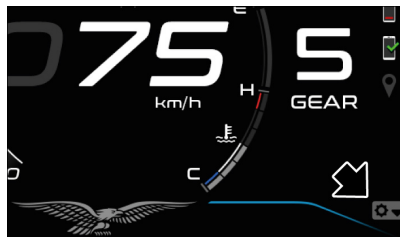

**WARNING**



**THE CLUTCH MUST BE USED FOR UPSHIFTS AT ENGINE SPEEDS BELOW 2000 rpm.**

**N.B.:**



**THE SYSTEM IS ACTIVE WHEN SHIFTING UP ONLY WITH THE THROTTLE OPEN.**

It can operate when downshifting as long as all the required conditions are met, including an rpm less than the maximum threshold, which varies according to the gear. If the downshifting system is not available temporarily for some reason (e.g. RPM too high, first gear engaged), the instrument panel icon will be orange.

If the icon lights red, it means that the electronic Quick Shift system is disabled due to a problem.



In this case carry out the following operations:

- stop the vehicle;
- turn the key OFF-ON and wait at least 40 sec. before turning the key ON again;
- exceed a speed of 5km/h (3.1 mph), if the light goes out the system is now active;

If the icon continues to be red, please contact an **OFFICIAL Moto Guzzi DEALER.**

**FACTORY SETTINGS**

**MGQS - Moto Guzzi Quick Shift (if applicable)**

It is a system that allows go up and down the gears without having to use the clutch and without changing the position of the throttle grip.

**SPORT:** MGCM: 1 - MGCT: 1 - MGCA: OFF  
- MGCS: A1

**ROAD:** MGCM: 2 - MGCT: 2 - MGCA: OFF  
- MGCS: A1

**TOURISM:** MGCM: 2 - MGCT: 3 - MGCA:  
Based on speed - MGCS: A2

**RAIN:** MGCM: 3 - MGCT: 2 - MGCA: ON -  
MGCS: A2

**MGCM: LEVEL 3 IS TO BE USED IN POOR  
GRIP, RAIN CONDITIONS.**

**MGCT: LEVEL 3 IS TO BE USED IN POOR  
GRIP, RAIN CONDITIONS.**

**N.B.:**



**THE TABLE SHOWS THE MAXIMUM  
INDICATIONS ON THE SETTING  
LEVELS OF THE VARIOUS  
CONTROLS. EACH RIDER MAY  
PERSONALISE THE LEVELS TO THEIR  
OWN PREFERENCE IN ACCORDANCE  
WITH ABILITY, RIDING STYLE AND  
ROAD CONDITIONS.**

**FOR MORE INFORMATION ON LEVEL  
SETTINGS, SEE THE RELATIVE  
SECTIONS FOR EACH INDIVIDUAL  
FUNCTION.**

**MGCT system warning light key**

- **Indicator light off:** with system activated with vehicle in motion or system activated after exceeding 5 Km/h (3.1 mph) after key-on;

- **Indicator light continuously lit:** system deactivated deliberately by rider, or deactivated as a result of a malfunction;

- **Indicator light flashing slowly:** with the system active after key-on before exceeding 5 Km/h (3.1 mph) or in the case of certain malfunctions causing MGCT level to be locked ("+" and "-" buttons disabled);

- **Indicator light flashing quickly:** when MGCT system is effectively implementing traction control.



**Control buttons**

The control buttons on the left hand light switch may be used to navigate within the different screens of the system, view trip A / B log information and, if the vehicle is equipped with the GMP unit (Guzzi Multimedia Platform), also access phone information and music and media content.

The navigation buttons are as follows:

1. **MODE SET** (select / confirm / press and hold to reset)
2. **MODE UP** (up)
3. **MODE DOWN**
4. **MODE RIGHT** (right)

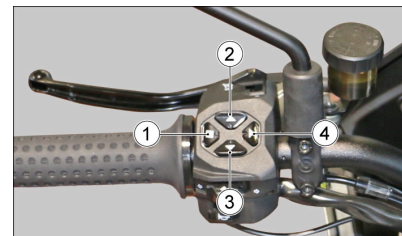

Using the "cruise" selector on the left-hand light switch is it possible to:

**With cruise control deactivated:**

- Change the intervention level of the MGCT traction control by pressing the selector up or down;
- Activate cruise control by briefly pressing the selector switch to the left (for more information see Digital Display - Cruise Control).

**With cruise control active:**

- increase or decrease the set cruising speed;

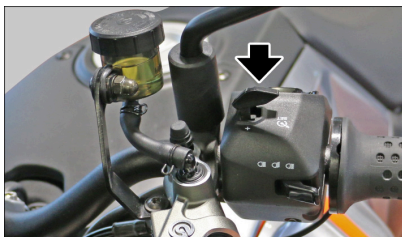

A number of different symbols (such as the examples (1) and (2) shown in the figure) may be displayed in the pop-up space.

- Where shown as a solid shape (1), the symbol indicates that it is necessary to press and hold the relative control for the function described.
- Where shown as an outline only (2), the symbol indicates that it is necessary to press the relative control briefly and release for the function described.



When in ROAD mode (\*) only, pressing "MODE RIGHT" briefly repeatedly cycles through the following screens:

- A) Trip log A.

- B) Trip log B.
- C) Heated hand grip info (if applicable)
- D) Heated saddle information (where provided)
- E) Tyre pressure info (if applicable)
- F) Phone information. (if applicable)
- G) Music information. (if applicable)
- H) Multimedia information. (if applicable)

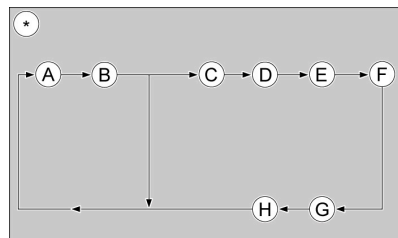

When in NAVI mode (\*\*), pressing "MODE RIGHT" briefly repeatedly cycles through the following screens:

- A) Trip log A.
- B) Trip log B.
- C) Heated hand grip info (if applicable)
- D) Heated saddle information (where provided)
- E) Tyre pressure info (if applicable)
- F) Phone information. (if applicable)
- G) Music information. (if applicable)
- H) Multimedia information. (if applicable)
- I) Navigation information. (if applicable)

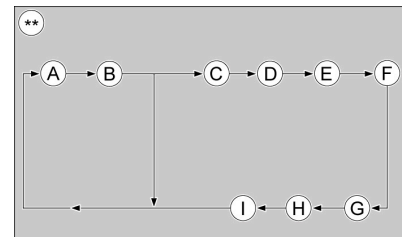

**A) - B) Trip log (displayed in ROAD / NAVI modes)**

There are two trip logs available, log A and log B.

Press "MODE UP" or MODE DOWN" button briefly to cycle through the following information on the digital display, in the indicated order:

- ODOMETER.
- TRIP ODOMETER.
- TRIP TIME.
- MAXIMUM SPEED.
- AVERAGE SPEED.
- AVERAGE FUEL CONSUMPTION.
- INSTANTANEOUS FUEL CONSUMPTION.
- DRIVING IN RESERVE (only when the reserve indicator is on).
- MGCT (Moto Guzzi Traction Control)

From any of the following view modes: TRIP ODOMETER, TRIP TIME, MAXIMUM SPEED, AVERAGE SPEED or AVERAGE FUEL CONSUMPTION, press and hold

MODE SET to reset all the values logged in the currently active TRIP LOG.



**C) Heated grips information (displayed in ROAD / NAVI modes) (if applicable)**

This menu provides information about the heated grips including the activation status and the heating intensity.

For further details, see paragraph "Heated grips control".



**D) Heated saddle information (displayed in ROAD / NAVI modes only) (where applicable)**

This menu provides information about the heated saddle, including the activation status and the heating intensity.

For further details, see paragraph "Heated saddle control".



**E) Tyre pressure information (displayed in ROAD and NAVI modes) (where provided)**

Select this screen to view information relative to tyre pressure and temperature and possible alarms.



**F) Phone information (where provided)**

Information relative to phone calls is displayed in this menu, such as:

- Call in progress.
- Incoming call.
- Outgoing call.

- Call ended.
- Voice control active.
- Call log.

See the chapter "ADVANCED FUNCTIONS" for more details.

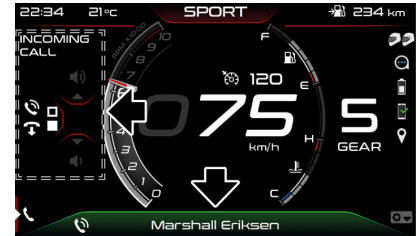

**G) Music information (displayed in ROAD / NAVI modes) (where provided)**

Information relative to audio playback is displayed in this menu, such as:

- Track playing.
- Playback paused.

See the chapter "ADVANCED FUNCTIONS" for more details.

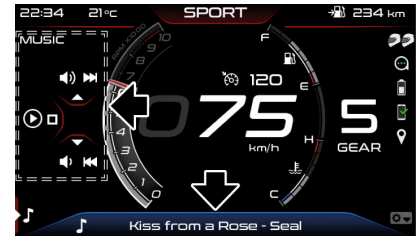

**H) Media information (where provided)**

The vehicle is equipped with the "MOTO GUZZI MIA" accessory, which communicates with the smartphone via Bluetooth. Using the specific "MOTO GUZZI" application installed on the smartphone, it is possible to exchange data with the vehicle and manage multimedia contents. Once a connection is established correctly between the control unit and smartphone, the following functions can be directly managed by the digital display of the vehicle:

- call management;
- manage audio playback;
- GPS navigation.



The "MULTIMEDIA" sub-menu of the main "MENU" contains 3 functions:

- Devices status (list of equalised devices)
- Reset pairing (reset of all paired devices)
- Devices pairing (allows the pairing of new devices)

Having activated the Bluetooth function on the device to be paired, by briefly pressing

the MODE RIGHT button, selecting the "Devices pairing" command from the vehicle menu, the devices available for pairing will be scanned.

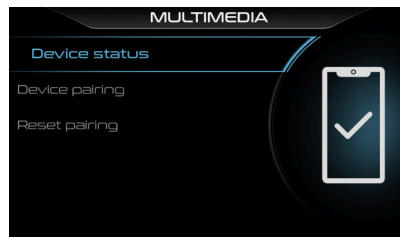

Once the device to be paired has been identified, after selecting it, by briefly pressing the MODE RIGHT button, pairing will be carried out and the screen will return to the ROAD mode display with a pop-up confirming "PAIRING COMPLETED" or "PAIRING ABORTED" if the pairing does not take place correctly.



The smartphone icon on the display indicates active communication. **When requested, allows phone book and notifications sharing. These enabling**

**operations are necessary to display the caller's name on the display.**

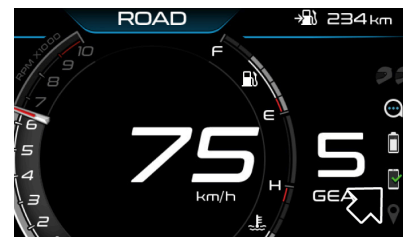

**N.B.:**



**UPON THE FIRST PAIRING BETWEEN THE DISPLAY AND SMARTPHONE, MORE TIME MAY BE REQUIRED FOR THE SYNCHRONIZATION OF THE PHONE BOOK.**

**THE CONNECTION BETWEEN THE SMARTPHONE AND VEHICLE WILL BE SIGNALLED BY THE LIGHTING OF THE SMARTPHONE ICON ON THE DISPLAY.**

**CONNECTION BETWEEN THE APPLICATION AND THE DIGITAL DISPLAY**

Search for the "Moto Guzzi" application in Play Store or App Store and install it. Register your account by following the instructions. Select "allow" for the position and notifications management requests.

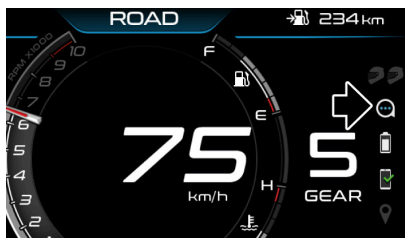

### PAIRING A BLUETOOTH HEADSET FROM THE APP

Multimedia functions may be accessed using the MODE buttons if a bluetooth headset is paired with the digital display using the "Moto Guzzi" app. (This can also be performed from the instrument panel without using the application). After pairing it will be possible to answer or reject calls, activate voice commands and control the music on the smartphone.

Activate the "pairing" mode of the bluetooth headset to be paired (refer to the instructions of the device itself). Press the Bluetooth icon on the main screen of the "Moto Guzzi" application and perform a new search for devices until the headset is displayed. Select the bluetooth headset, check the "Handsfree/driver headset" option and press "Pair". Successful pairing is indicated by the helmet icon displayed on the digital display. If the pairing is not successful, perform a new search.

Repeat the operation to connect a second device also. If this pairing procedure is

successful, the 2nd helmet icon will be highlighted in black on the digital display.

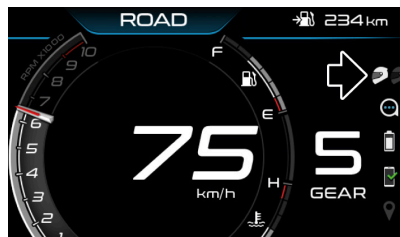

No multimedia function can be managed from the handlebar of the vehicle if there is no bluetooth headset, or if the headset is directly connected to the smartphone.

**The Bluetooth headset can be paired with the vehicle only via the "Moto Guzzi" application and it must be connected to the vehicle in order to correctly use the multimedia functions of the system. For this reason, the headsets that automatically connects to the smartphone are not compatible (Ex: Apple AirPods).**



**If pairing between Smartphone and Vehicle is not successful, proceed as follows:**

- restart the smartphone;
- turn the ignition key to "OFF" and then to "ON"; wait for the animation on the display to end.

If the smartphone icon on the display is not illuminated after approximately 1 minute, proceed as follows;

- open "Moto Guzzi" and select "Connect";
- select your vehicle from the list of suggestions and follow the instructions on the device;
- once the Application is connected, select the Bluetooth icon that appears on the main screen;
- open the Bluetooth devices menu;
- select "Configure" and delete all paired devices, leaving the current device till last, or perform the operation from the vehicle MENU;
- make sure that the application icon on the display is off;
- turn the ignition key to "OFF" and then to "ON", then wait until the animation on the screen ends;
- the display must show the pop up "No connected device";
- repeat the pairing procedure from the start.

**N.B.:**



PLEASE NOTE THAT TO CONNECT THE APP TO THE VEHICLE AGAIN, THE FOLLOWING WILL BE NECESSARY:

- ON iOS, DELETE THE PREVIOUSLY INSTALLED APP AND REINSTALL IT.
- ON ANDROID, SIMPLY DELETE THE APPLICATION DATA FROM THE APP MANAGEMENT MENU (THIS WILL RETURN THE APPLICATION TO THE INITIAL CONDITION AND THE LOGIN AND FIRST CONNECTION TO THE VEHICLE MUST BE PERFORMED AGAIN).
- IN CASE OF CONNECTION TO A NEW VEHICLE, IT IS NECESSARY TO REMOVE THE PREVIOUS BT-ROUTER FROM THE ASSOCIATED DEVICES.

N.B.:



IT IS RECOMMENDED TO PAIR A MAXIMUM OF 2 SMARTPHONES AND 2 HEADSETS TO THE SAME VEHICLE, TO OPTIMIZE THE OPERATION OF THE SYSTEM.

IN CASE OF PAIRING THE SECOND SMARTPHONE, NOTE THAT THE SECOND ONE WILL REQUIRE A LONGER TIME (MORE THAN 30 SECONDS) TO CONNECT TO THE "BT-ROUTER". ONCE THE SMARTPHONE IS CONNECTED TO THE "BT-ROUTER", THE OPERATING SYSTEM WILL REQUEST ACCESS TO THE PHONE BOOK AND TO THE NOTIFICATIONS; ACCEPT TO DISPLAY THE NAMES OF THE CALLERS ON THE DISPLAY.

Required operation for iOS 10.0 versions or higher

If the "BT-ROUTER" device does not automatically request permission to share notifications, the following procedure is necessary:

- Enter the menu: "Settings" > "Bluetooth" > "Phone devices";
- select "BT-ROUTER", select "Info", enable the options manually.

#### INTERCOM AND VOCAL COMMANDS MANAGEMENT

The "Moto Guzzi" system manages the connection between the intercom and smartphone upon activation by the user.

#### WARNING



FOR SAFETY REASONS, IT IS RECOMMENDED TO CARRY OUT THE ACTIVATION / DEACTIVATION PROCEDURES WITH THE VEHICLE AT A STANDSTILL

To activate the "INTERCOM" function, press and hold the MODE SET button from the "Media information" screen.

A pop-up with the message "INTERCOM ON" will be shown on the digital display.



Pressing the MODE SET button briefly again deactivates the connection. The state "INTERCOM OFF" is now shown on the digital display.



To activate the "VOICE" function, which allows the user to access and use functions of their smartphone with voice commands from the headset (e.g. via Siri or Google Assistant), select the function with the MODE UP or MODE DOWN buttons and then press MODE SET briefly.



**N.B.:**



**THE "VOICE" FUNCTION CANNOT BE ACTIVATED IF THE "INTERCOM" FUNCTION IS ALREADY ACTIVATED.**

**l) Navigation information (displayed in NAVI mode only) (where applicable)**

Select this screen to view the destination for the navigation system entered via the smartphone.

**" Guzzi MIA" SYSTEM MESSAGES**

The "Guzzi MIA" system communicates with the user through messages that can be

viewed on the graphic panel of the digital display. Depending on the message type, the graphic panel shows the icon, colours and the specific message.

The following information is displayed:

- Information messages related to the infotainment system.

**CALL MANAGEMENT**

To use phone features, view caller notifications and identifiers, it is necessary to:

- pair the smartphone with the "Guzzi MIA" system via Bluetooth, as previously described;
- install the "Moto Guzzi" app on your smartphone and access it (can be performed also from the instrument panel, without using the application);
- pair a bluetooth headset with the "Guzzi MIA" system using the "Moto Guzzi" app (or from the dashboard instrument panel, without using the application);
- allow sharing of the phonebook and notifications when the smartphone is paired with the "Guzzi MIA" system.

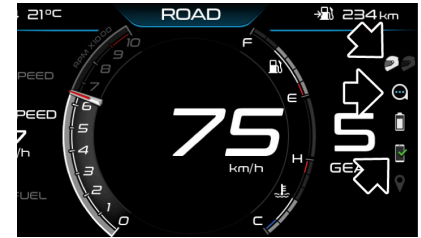

**N.B.:**



**WHEN A SMARTPHONE CONNECTS WITH THE «MOTO GUZZI MIA» SYSTEM (BT-ROUTER), AUDIO IS AUTOMATICALLY ROUTED TO THE MOTO GUZZI MIA SYSTEM.**

**IF THERE IS NO HEADSET CONNECTED TO THE "MOTO GUZZI MIA" SYSTEM, THE AUDIO FUNCTION OR MUSIC PLAYBACK CANNOT BE MANAGED, THEREFORE THE SMARTPHONE AUDIO MUST BE MANUALLY ROUTED TO THE DESIRED DEVICE (E.G. SPEAKERS/ TELEPHONE MICROPHONE).**

The following information is shown in the relative area on the digital display:

- call in progress;
- call ended;
- voice control active;

- incoming call;
- outgoing call;
- call log.

Press and hold MODE SET to enable voice commands. Press MODE DOWN or MODE UP briefly to scroll through the log of all calls (missed calls, calls made, outgoing calls made with no reply).

Select the required log entry and then press and hold MODE SET to call the relative contact.

#### MODE SELECTOR FUNCTIONS FOR CALL MANAGEMENT

- Accept incoming call: PRESS MODE SET SHORT
- End an active call: PRESS AND HOLD MODE SET
- Reject incoming call: PRESS AND HOLD MODE SET
- Cancel outgoing call: PRESS AND HOLD MODE SET
- Activate volume control (with call in progress): PRESS AND HOLD MODE UP OR MODE DOWN
- Increase volume (with call in progress): PRESS MODE UP BRIEFLY
- Lower volume (with call in progress): PRESS MODE DOWN BRIEFLY

#### MANAGING A SECOND CALL

If the smartphone paired with the "Guzzi MIA" system is capable of receiving a second incoming call, a number of functions for managing a second call are available.

A popup appears on the digital display showing the identification details of the current and of the new incoming call are displayed in alternation (at intervals of approximately 1 second).

#### FUNCTIONS OF MODE SELECTOR FOR MANAGING SECOND CALL

- Accept incoming call and put current call on hold: PRESS MODE SET BRIEFLY
- Reject incoming call and continue current call: PRESS AND HOLD MODE SET
- Switch between calls: PRESS MODE SET BRIEFLY

#### MUSIC PLAYBACK MANAGEMENT

To use the functions of the music player, the following must be performed:

- pair the smartphone with the "**Guzzi MIA**" system via Bluetooth, as previously described;
- install the "**Moto Guzzi**" app on your smartphone and access it (can be performed also from the instrument panel, without using the application);
- pair a bluetooth headset with the "**Guzzi MIA**" system using the "**Moto Guzzi**" app (or from the dashboard instrument panel, without using the application).

The corresponding three icons are shown on the digital display.



#### N.B.:



**WHEN A SMARTPHONE CONNECTS WITH THE «MOTO GUZZI MIA» SYSTEM (BT-ROUTER), AUDIO IS AUTOMATICALLY ROUTED TO THE MOTO GUZZI MIA SYSTEM.**

**IF THERE IS NO HEADSET CONNECTED TO THE "MOTO GUZZI MIA" SYSTEM, THE AUDIO FUNCTION OR MUSIC PLAYBACK CANNOT BE MANAGED, THEREFORE THE SMARTPHONE AUDIO MUST BE MANUALLY ROUTED TO THE DESIRED DEVICE (E.G. SPEAKERS/ TELEPHONE MICROPHONE).**

The following information appears on the digital display:

- Track playing;
- playback paused;
- playback interrupted.

Use the MODE buttons to manage audio playback as shown below:

**MODE SELECTOR FUNCTIONS FOR MUSIC MANAGEMENT**

Play track: PRESS MODE SET BRIEFLY

Activate volume control (with call in progress): PRESS AND HOLD MODE UP OR MODE DOWN

Increase volume (with call in progress): PRESS MODE UP BRIEFLY

Turn the volume down (with call in progress): PRESS MODE DOWN BRIEFLY:

Next track: PRESS MODE UP BRIEFLY

Previous audio track: PRESS MODE DOWN BRIEFLY

Siri activation: PRESS AND HOLD MODE SET

**Advanced functions**

With a long press of the MODE RIGHT button, from the ROAD screen, the display will pass to the NAVI screen (if the Guzzi MIA ECU is present) and then to the MENU screen.

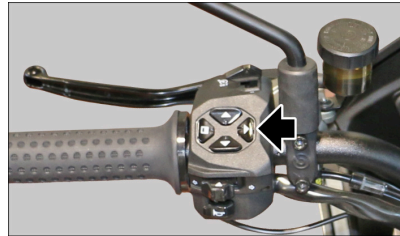

The flow diagram below shows the structure of the menu; the submenus of each function are explained in the relevant paragraphs in this section.

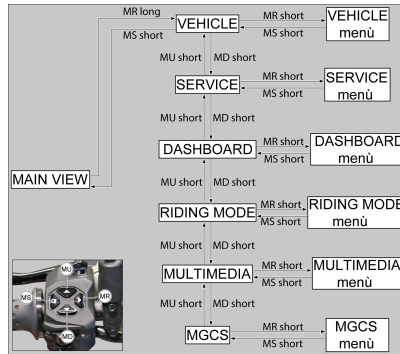

The menu is composed of the following entries:

- 1) Vehicle
- 2) Service
- 3) Instrument cluster
- 4) Riding mode

5) Multimedia - if applicable

6) MGCS (Moto Guzzi Suspension Control) - **where required**

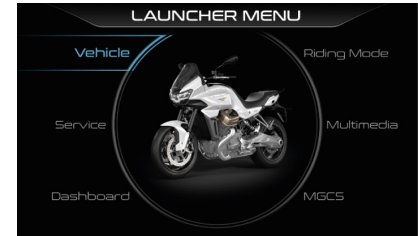

**1) Vehicle**

The "Vehicle" menu contains the following options:

- 1.1) Headlamp mode - where required
- 1.2) Shift light
- 1.3) MGQS down - where required
- 1.4) Emergency brake (Brake light)
- 1.5) Calibration
- 1.6) Front radar F.C.W. (Front radar) **where required**
- 1.7) Rear radar L.C.D.A.S. (Rear radar) - **where required**

The functions available in the "Vehicle" menu are described in the following paragraphs.

To access the selected menu, briefly press the MODE RIGHT button, and to return to

the main "MENU", briefly press the MODE SET button.



### 1.1) Headlamp mode - if applicable

This function is used to set the operating mode of the lights.

The use mode can be selected by shortly pressing the MODE RIGHT button. These modes will be displayed cyclically every time you press the button.

Auto = Automatic

Manual = Manual

Emergency = Emergency; (emergency mode must only be used in the event of a malfunction of the headlamp; and enables usage of the low beam headlights and DRL lights only)

Press MODE SET briefly to go back to the main MENU.

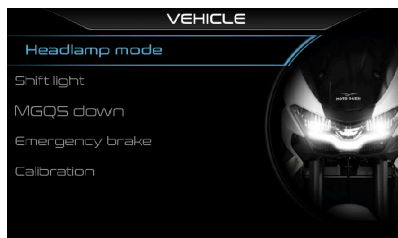

**N.B.:**



**THE RELATIVE ICON IS SHOWN ON THE DIGITAL DISPLAY WHEN "AUTO" MODE IS ACTIVE.**

### 1.2) Shift light

This function is used to set the rotation threshold; if this is exceeded, the engine rpm bar will flash and the immobilizer indicator light will switch on.

The threshold can be increased by shortly pressing the MODE RIGHT button.

Once the maximum rotation number is reached, the threshold starts again from 4000 rpm.

Press MODE SET briefly to exit edit mode.

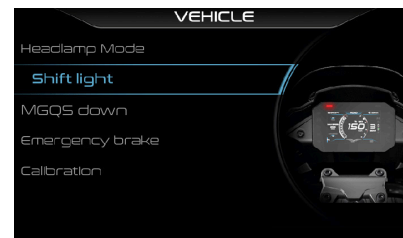

### 1.3) MGQS down - where required

This function may be used to enable or disable the automatic matching system allowing **downshifts** without using the clutch.

The activation status can be changed by briefly pressing the button. The function will be cyclically changed by further pressing the MODE RIGHT button.

Press MODE SET briefly to go back to the main MENU.

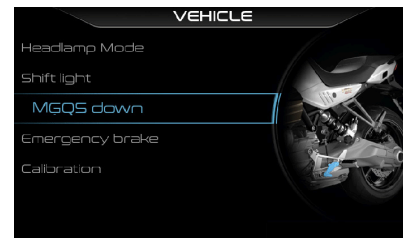

### MGQS ICON KEY:

White icon = MGQS active

GREY ICON = MGQS disabled by user

ORANGE ICON: MGQS is temporarily unavailable (e.g. due to too high RPM, first gear engaged, etc.)

RED ICON: MGQS is disabled due to a problem. In this case carry out the following operations:

- stop the vehicle;
- turn the key OFF-ON and wait at least 40 sec. before turning the key ON again;
- exceed a speed of 5km/h (3.1 mph), if the light goes out the system is now active;

If the icon continues to be red, please contact an **OFFICIAL Moto Guzzi DEALER**.



#### 1.4) Emergency brake (Brake light)

When enabled, this function automatically activates the hazard warning lights in the event of hard and/or sudden braking. Activation of the hazard warning lights is not dependent on whether the ABS system is triggered.

If it is not active, a brief press on the MODE RIGHT button will activate the function and a further press will deactivate it again.

Press MODE SET briefly to go back to the main MENU.

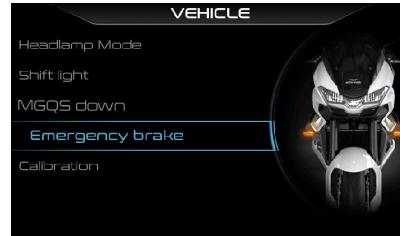

#### 1.5) Calibration

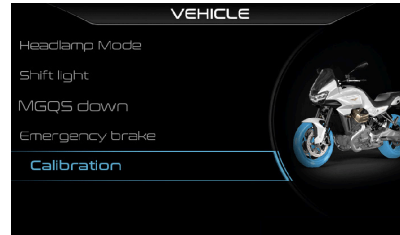

When the Calibration function is selected (with the vehicle stationary), having activated it by pressing the MODE RIGHT button briefly, a screen appears in the Pop-up area with the following description: "Calibration - Speed not correct"



To calibrate the MGCT system (Moto Guzzi Traction Control) ride along a flat straight road in second gear at a speed of 40 +/- 2 km/h (24.85 +/- 1.24 mph) for approximately 10 seconds, until the digital display shows a message "Calibration - Hold speed".



If calibration is completed successfully, the message "Calibration done - Key OFF (60s)" is displayed.



**N.B.:**



WHEN THE TEXT "Calibration done - Key OFF (60s)" APPEARS ON THE DISPLAY, STOP THE VEHICLE AND TURN THE IGNITION TO KEY-OFF FOR AT LEAST 60 SECONDS TO COMPLETE CALIBRATION. THIS ALLOWS THE CALIBRATION TO BE STORED IN THE MEMORY.

**N.B.:**



THE CALIBRATION OPERATION IS USED TO OPTIMISE THE MGCT FUNCTION IN CASE OF A CHANGE IN TYRE TYPE.

IF TYRES OTHER THAN THOSE INDICATED IN THIS USE AND MAINTENANCE BOOKLET ARE USED, TO OBTAIN THE SAME PERFORMANCE FROM THE MGCT SYSTEM THE SETTING LEVELS OF THE SYSTEM ITSELF MAY NEED TO BE MODIFIED.

**N.B.:**



TURN THE IGNITION SWITCH OFF TO ABORT THE CALIBRATION PROCEDURE.

DURING CALIBRATION, MGCT IS AUTOMATICALLY DEACTIVATED (IF PREVIOUSLY ACTIVATED).

#### 1.6) Front Radar (FCW) - (where required)

This menu allows to activate or deactivate the front radar F.C.W - Frontal Collision Warning and also to activate or deactivate its acoustic signals.

**CAUTION**



**DRIVER ASSISTANCE SYSTEMS PROVIDE USEFUL INFORMATION**

TO IMPROVE DRIVING COMFORT AND CAN IMPROVE THE DRIVER'S PERCEPTION OF THE OPERATING ENVIRONMENT.

THESE SYSTEMS CAN IN NO WAY BE CONSIDERED SAFETY SYSTEMS AND THE DRIVER REMAINS SOLELY RESPONSIBLE FOR ASSESSING VISIBILITY AND TRAFFIC CONDITIONS AND TAKING THE NECESSARY ACTIONS TO AVOID ACCIDENTS OR TRAFFIC VIOLATIONS.

RADAR-BASED SYSTEMS CANNOT DETECT STATIONARY OBJECTS OR OBJECTS MOVING AT LOW SPEED. THEY ARE THEREFORE UNABLE TO INTERVENE IN THE CASE OF PEDESTRIANS, SLOW-MOVING CAR QUEUES, BICYCLES AND SIMILAR.

SIMILARLY, THE DISTANCE AT WHICH OBJECTS ARE RECOGNISED DEPENDS ON THEIR SHAPE, SO EFFECTIVENESS MAY VARY DEPENDING ON THE TYPE OF VEHICLE.

DUE TO INHERENT LIMITATIONS OF RADAR TECHNOLOGY AND THE REDUCED FIELD OF VIEW OF THE SENSORS, IT IS POSSIBLE THAT SOME VEHICLES MAY NOT BE DETECTED, DETECTED LATE, OR DETECTED WHEN NOT PRESENT UNDER THE FOLLOWING CONDITIONS:

- **DRIVING AT A VEHICLE ANGLE OF MORE THAN 20°**
- **STRAIGHT CURVES**
- **DRIVING UNDER HEAVY ACCELERATION OR BRAKING**
- **VEHICLES THAT SUDDENLY ENGAGE THE MOTORBIKE LANE**
- **SLOW-MOVING OR STATIONARY VEHICLES**
- **BIFURCATIONS OF THE ROAD**
- **LANE NARROWINGS**
- **BRIDGES, TUNNEL ENTRANCES OR EXITS, LARGE ROAD SIGNS**
- **OBJECTS LIFTED BY THE WIND (PLASTIC BAGS, BALLS, NEWSPAPERS...)**

To access the selected menu, briefly press the MODE RIGHT button, and to return to the main "MENU", briefly press the MODE SET button.



Once in the menu, the system state can be set by briefly pressing the MODE RIGHT button, which will cycle through the three possible states:

Radar disabled (OFF): on the dashboard the icon shown in the figure coloured dark grey will be displayed.



Radar enabled: on the dashboard you will see the icon shown in the figure coloured white.



Radar enabled with sound disabled: the radar icon will be added to the sound disabled icon.



If enabled, this function signals the presence of obstacles approaching from the front of the vehicle by means of acoustic signals and light signals on the display. In the case of an approaching object, with danger of a front collision, there will be two alert levels:

**Level 1:**

Level 1 warnings indicate a failure to observe the safety distance; the front collision icon will appear in the upper area of the dashboard, NO acoustic signal will be activated.



**Level 2:**

If the distance between the vehicle and the approaching object decreases, the Forward

Collision Warning icon will be displayed on a red background in the centre of the dashboard, the pop-up area will turn red and the words "Forward Collision Warning" will appear with the warning triangle to the side accompanied by an acoustic signal (if active). This level indicates an **imminent danger of collision** and requires the driver to brake hard.

If the distance between the vehicle and the approaching object increases, the warnings will end.



In the event of a front radar malfunction, the pop-up area of the dashboard will turn orange and the words "Front Radar Disabled" will appear with the warning triangle to the side.



**CAUTION**



**IT IS RECOMMENDED THAT YOU NEVER COVER THE RADAR WITH ANY TYPE OF OBJECT (STICKERS, CLOTHING, ...) AND TO KEEP IT CLEAN ALWAYS FOR PROPER OPERATION.**

**IF AN OBJECT COVERS THE RADAR FOR MORE THAN 30 SECONDS, THE RADAR WILL TURN OFF AND THE DIGITAL DISPLAY WILL DISPLAY A WARNING MESSAGE.**



**1.7) Rear Radar (L.C.D.A.S.) (Rear radar) - (where required)**

This menu enables or disables the vehicle's rear radar L.C.D.A.S. - Lane Change Decision Aid System.

To access the selected menu, briefly press the MODE RIGHT button, and to return to the main "MENU", briefly press the MODE SET button.



Once in the menu, the system state can be set by briefly pressing the MODE RIGHT button, which will cycle through the two possible states:

Radar disabled (OFF): on the dashboard the icon shown in the figure coloured dark grey will be displayed.



Radar enabled: on the dashboard you will see the icon shown in the figure coloured white.





**CAUTION**  
  
**IF ACTIVATED, THE REAR RADAR DOES NOT DETECT VEHICLES THAT FOLLOW YOUR VEHICLE IN A ROW,**

**BUT ONLY THOSE COMING FROM THE ADJACENT ROADWAYS**

**N.B.:**  
  
**THE DISTANCE AT WHICH THE VEHICLES COMING Laterally CAN BE DETECTED BY THE REAR RADAR DEPENDS ON THE SHAPE AND TYPE OF THE VEHICLE ITSELF.**

When activated, this function signals the presence of vehicles coming from the areas immediately to the rear of the vehicle by means of light signals on the display and the relevant rear-view mirror. It also allows the detection of vehicles in the blind spots of rear view mirrors or fast approaching vehicles on the left and right side of the vehicle. It is therefore used to avoid changing directions if there is another vehicle nearby that is not easy to spot.



**CAUTION**  
  
**IT IS RECOMMENDED THAT YOU NEVER COVER THE RADAR WITH ANY TYPE OF OBJECT (STICKERS, CLOTHING, ...) AND TO KEEP IT CLEAN ALWAYS FOR PROPER OPERATION.**  
**IF AN OBJECT COVERS THE RADAR FOR MORE THAN 30 SECONDS, THE RADAR WILL TURN OFF AND THE DIGITAL DISPLAY WILL DISPLAY A WARNING MESSAGE.**

**CAUTION**

IF ACTIVATED, THE REAR RADAR WILL OPERATE AT A SPEED OF AT LEAST 30 KM/H AND FOR A VEHICLE LEAN ANGLE OF MAXIMUM 20°.

THE OPTIMUM OPERATION OF THE SYSTEM IS STILL ENSURED ON A STRAIGHT ROAD.

**N.B.**

IF DIFFERENT WHEEL SPEEDS ARE DETECTED (E.G. SKIDDING) THE L.C.D.A.S. SYSTEM IS TEMPORARILY DEACTIVATED.

In the event of a rear radar malfunction, the pop-up area of the dashboard will

turn orange and the words "Rear Radar Disabled" will appear with the warning triangle to the side.

**CAUTION**

THE DRIVER OF A VEHICLE IS RESPONSIBLE FOR DRIVING AND MANOEUVRING EVEN IF THERE ARE INTELLIGENT DRIVING AID SYSTEMS ON THE VEHICLE, SUCH AS THE L.C.D.A.S. SYSTEM. (LANE CHANGE DECISION AID SYSTEM) AND CRUISE CONTROL, WHICH MUST ALWAYS BE CHECKED OR CORRECTED BY THE DRIVER. THESE SYSTEMS ARE ONLY DESIGNED TO ASSIST THE DRIVER DURING DRIVING AND TO IMPROVE THE DRIVING CONDITION.

THE DRIVER IS ALWAYS RESPONSIBLE FOR THE CHOICE OF DRIVING BEHAVIOUR AND FOR THE ADOPTION OF THE LEVEL OF CAUTION AND ATTENTION REQUIRED

**BY THE SPECIFIC ENVIRONMENTAL CONTEXT.**

**CAUTION**

THE DRIVER IS ALWAYS THE ONE RESPONSIBLE FOR THE ROAD SAFETY.

THE SYSTEM DOES NOT REPLACE THE REAR VIEW MIRRORS AND IS NOT INTENDED TO PREVENT COLLISIONS, BUT TO PROVIDE VISUAL INFORMATION THAT THE DRIVER CAN USE TO PREVENT THEM, IF POSSIBLE. THEREFORE, THE DRIVER MUST NOT RELY EXCLUSIVELY OR UNWISELY ON THE "CAPABILITIES" OF THE SYSTEM TO UNDERSTAND THE ENVIRONMENT: THE SHAPE OF CERTAIN OBJECTS, THEIR SURFACE, THEIR STATIC/DYNAMIC POSITION, THE MANNER IN WHICH THEY ENTER THE RADAR'S VISUAL SPACE MAY NOT BE ENOUGH FOR THE SYSTEM TO UNDERSTAND SAID CONTEXT AND CAUSE THE DRIVER TO RECEIVE INCORRECT INFORMATION.

**N.B.:**



**THE PERFORMANCE OF THE L.C.D.A.S. SYSTEM. IS NOT AFFECTED BY AMBIENT LIGHTING BUT MAY VARY DEPENDING ON WEATHER OR ROAD CONDITIONS. IN PARTICULAR, SNOW, HEAVY RAIN OR WATER STAGNATION MAY REDUCE THE CAPACITY OF THE SYSTEM OR, IN GENERAL, LEAD TO INCORRECT INDICATIONS.**

## 2) Service

The "Service" menu contains the following options:

- 2.1) Change user code
- 2.2) Code recovery
- 2.3 Windshield
- 2.4) Application (Firmware version)
- 2.5) Boot loader (Firmware version)
- 2.6) HLU application (Firmware version)

The functions available in the "Service" menu are described in the following paragraphs.

To access the selected menu, briefly press the MODE RIGHT button, and to return to the main "MENU", briefly press the MODE SET button.

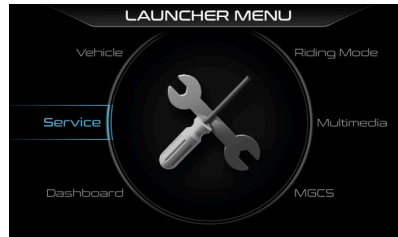

### 2.1) Change user code

This function may be used to modify the existing code (you must be in possession of the code itself in order to do this). The user code enables engine start even in the event of an immobiliser system fault. On a new vehicle, the user code is set by default as five zeros (00000) and the message "INSERT YOUR PERSONAL CODE" appears on the display for ten seconds when the ignition is switched on.

This function allows you to change the code itself and remove this message.

The leftmost value of the display will show a value from 0 to 9 (which can be changed by pressing the MODE UP or MODE DOWN keys). Press MODE SET briefly to confirm the selection. Repeat the operation for all the digits. Once the code is confirmed, the new code is shown steadily on the display to let the user verify that the code has been entered correctly. Turn the ignition off and then on again to unlock the instrument cluster.

The last code set may be modified again in the future.

Access the setting mode again, enter the last user code used (OLD CODE), then enter a new user code (NEW CODE) as described previously.

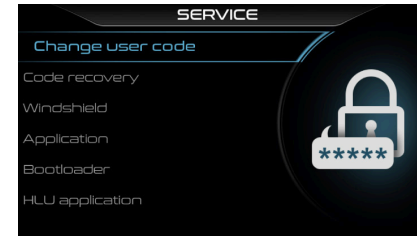

### 2.2) Code recovery

This function must be used should it be necessary to change the user code when the user no longer remembers the code currently in use. Both keys stored in the vehicle memory are needed to access this function.

Once the function is activated, pressing the MODE SET briefly displays the message "INSERT KEY 1", requesting identification of the first key. Insert the key. If the correct key is recognised within twenty seconds, the message "INSERT KEY 2" is shown on the display. Insert the second key. If the second key is also recognised within twenty seconds, the instrument cluster resets the user code to the default code (five zeros - 00000). Enter the new user code following the "CHANGE USER CODE" procedure.

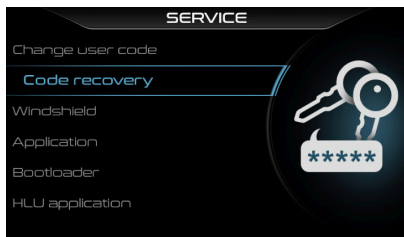

### 2.3) Windshield

This function also allows you to set the maximum speed at which the top fairing can be adjusted while riding, differentiating the setting for the two versions:

- **SMALL:** the top fairing can be adjusted up to a maximum speed of 130 km/h or 80 mph.
- **BIG:** the top fairing can be adjusted up to a maximum speed of 110 km/h or 68 mph.

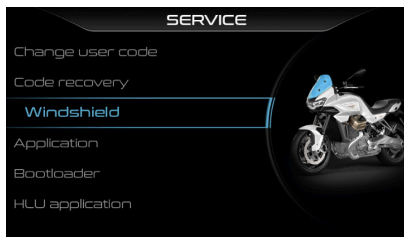

### CAUTION



**THESE LIMITS MAY BE REDUCED UNDER CERTAIN ENVIRONMENTAL CONDITIONS.**

### 3) Instrument cluster

The "Dashboard" menu contains the following options:

- 3.1) Backlight
- 3.2) Clock
- 3.3) Units
- 3.4) Language
- 3.5) Riding modes language

The functions available in the "Dashboard" menu are described in the following sections.

To access the selected menu, briefly press the MODE RIGHT button, and to return to the main "MENU", briefly press the MODE SET button.



### 3.1) Backlight

This function allows you to change the backlight of the digital display, from a minimum value of 1 to a maximum value of 10.

The back light intensity can be increased with one point by briefly pressing on the MODE RIGHT button. Once the maximum level is reached, a further press will restart the setting from the minimum value.

Keep the MODE RIGHT button pressed to continuously increase the value until the button is released.

Press MODE SET briefly to go back to the main MENU.



### 3.2) Clock

This menu allows to adjust the clock and change its display format. The menu is divided into the following items:

- 3.2.1) Minutes
- 3.2.2) Hours
- 3.2.3) 12 H or 24 H mode (12 H or 24 H display)

Press MODE SET briefly to go back to the "Dashboard" menu.

### 3.2.1) Minutes / 3.2.2) Hours / 3.2.3) 12H or 24H mode (12H or 24H display)

For the Minutes and Hours functions only, the value can be increased with one point with a brief press on the MODE RIGHT button. Once the maximum level is reached, a further press will restart the setting from the minimum value. Keep the MODE RIGHT button pressed to continuously increase the value until the button is released

For the 12H or 24H mode function only (12H or 24H display), briefly press the MODE RIGHT selector to change the time display format.

Press MODE SET briefly to go back to the "Clock" menu.



### 3.3) Units

This menu allows you to change the settings for displaying the units and is divided as follows:

#### 3.3.1) Speed

#### 3.3.2) Fuel consumption

#### 3.3.3) Temperature

#### 3.3.4) Pressure (visible if applicable)

Press MODE SET briefly to go back to the "Dashboard" menu.

#### 3.3.1) Speed

This function may be used to change the unit of measurement used for speed:

- km/h (kilometres per hour)
- mph (miles per hour)

The measurement unit can be changed by shortly pressing the MODE RIGHT button.

Press MODE SET briefly to go back to the "Dashboard" menu.

#### N.B.:



**IF THE UNIT OF MEASURE SET AT THE FACTORY HAS BEEN CHANGED, THE SPEED'S UNIT OF MEASURE WILL FLASH FOR 30 SECONDS EACH TIME THE KEY IS ENGAGED.**

#### 3.3.2) Fuel consumption

This function is used to change the display of the fuel consumption measurement unit:

- km/l
- l/100 km

- mpg (UK)
- mpg (USA)

The measurement unit can be selected by shortly pressing the MODE RIGHT button. These units will be displayed cyclically every time you press the button.

Press MODE SET briefly to go back to the "Dashboard" menu.

#### 3.3.3) Temperature

This function is used to change the measurement unit used for temperature:

- °C (Celsius degrees)
- °F (Fahrenheit degrees)

The measurement unit can be changed by shortly pressing the MODE RIGHT button.

Press MODE SET briefly to go back to the "Dashboard" menu.

#### 3.3.4) Pressure (visible if applicable)

This function is used to change the display of the tire pressure measurement unit:

- bar;
- psi.

The measurement unit can be changed by shortly pressing the MODE RIGHT button.

Press MODE SET briefly to go back to the "Dashboard" menu.

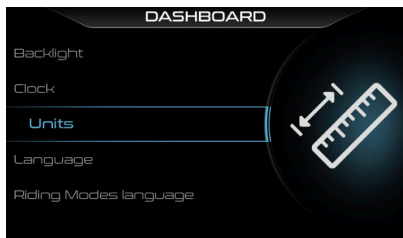

### 3.4) Language

This function is used to change the instrument panel display language:

- English
- Italian
- French
- German
- Spanish

The next language can be selected by shortly pressing the MODE RIGHT button. These languages will be displayed cyclically every time you press the button.

Press MODE SET briefly to go back to the "Dashboard" menu.



### 3.5) Riding modes language (Riding modes display language)

This function is used to change the Riding mode display language:

- Italian
- English

The next language can be selected by shortly pressing the MODE RIGHT button.

Press MODE SET briefly to go back to the "Dashboard" menu.



### 4) Riding mode (Riding mode) - if applicable

Each "Riding mode" is composed of the following entries:

MGCM (Moto Guzzi Engine Control)

MGCT (Moto Guzzi Traction Control)

MGCA (Moto Guzzi Aerodynamic Control) - **where required**

MGCS (Moto Guzzi Suspension Control) - **where required**

This function allows to edit the intervention level of each individual control system associated with the Riding mode selected.

To access the selected menu, briefly press the MODE RIGHT button, and to return to the main "MENU", briefly press the MODE SET button.

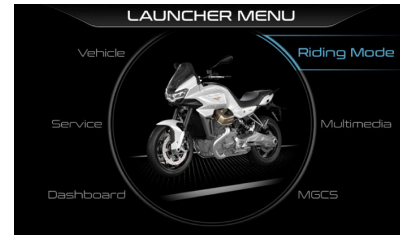

Using the MODE RIGHT button, select the RIDING MODE you want to edit, then use the MODE UP or MODE DOWN buttons to position on the item of which you want to edit and change the intervention level using the MODE RIGHT button.

For more information on the available settings, refer to the "**MGCT System**" section.

To reset the values to the factory settings, select the desired RIDING MODE and press and hold the MODE SET button.

Press MODE SET briefly to go back to the MENU.

	SPORT	ROAD	TOUR	RAIN
MGCM	1	2	1	2
MGCT	2	1	OFF	4
MGCA	ON 30 km/h	OFF	ON	ON -- km/h
MGCS	M1	M2	A2	A1

MODIFY → MOVE ↕ RESET ■ EXIT □

**N.B.:**



**Intervention RANGE**

**MGCM: 1 - 3 (1 = more aggressive intervention, 3 = softer intervention)**

**MGCT: OFF - 4 (4 = maximum intervention)**

**MGCA: you can select the speed at which the aerodynamic protections will open.**

**MGCS: M1, M2, A1, A2. (M = manual, A = automatic)**

**5) Multimedia**

The "Multimedia" menu consists of the following items:

- 5.1) Devices status
- 5.2) Devices pairing
- 5.3) Reset pairing

The functions available in the "Multimedia" menu are described in the following paragraphs.

To access the selected menu, briefly press the MODE RIGHT button, and to return to the main "MENU", briefly press the MODE SET button.



**5.1) Devices status**

The "Devices status" menu allows to view the list of paired devices.

Press MODE SET briefly to return to the "Multimedia" menu.

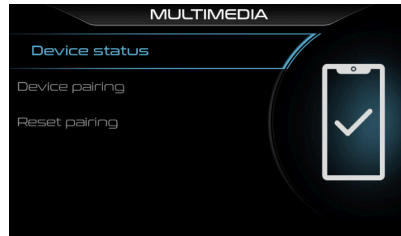

**5.2) Devices pairing**

The "Devices pairing" menu allows to pair new devices on the dashboard of the vehicle.

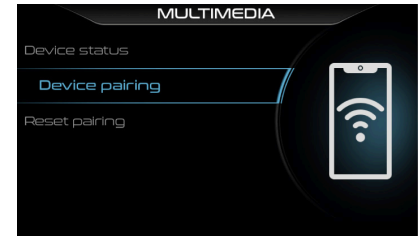

Having activated the Bluetooth function on the device to be paired, by briefly pressing the MODE RIGHT button, selecting the "Devices pairing" command from the vehicle menu, the devices available for pairing will be scanned.

Once the device to be paired has been identified, after selecting it, by briefly pressing the MODE RIGHT button, pairing will be carried out and the screen will return to the ROAD mode display with a pop-up confirming "PAIRING COMPLETED" or "PAIRING ABORTED" if the pairing does not take place correctly.

Press MODE SET briefly to return to the "Multimedia" menu.



### 5.3) Reset pairing

The "Reset pairing" menu allows to delete and consequently disconnect all paired devices by briefly pressing the "MODE RIGHT" button..

Press MODE SET briefly to return to the "Multimedia" menu.



### 6) MGCS (Moto Guzzi Suspension Control) - where required

The MGCS menu allows you to adjust the parameters of the OHLINS electronic suspension based on the preferences of the rider and the use conditions of the vehicle.

The changes made will be effective on all Riding modes.

The MGCS menu consists of the following entries:

6.1) Manual dynamic / Manual comfort

6.2) Automatic dynamic / Automatic comfort

To access the selected menu, briefly press the MODE RIGHT button, and to return to the main "MENU", briefly press the MODE SET button.

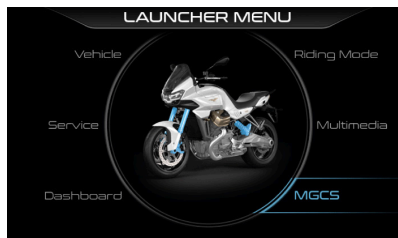

#### 6.1) Manual dynamic / Manual comfort

These menus allow modifying the suspension settings in "manual" mode, by operating electronically on the hydraulic settings. Each of the two modes is preset by the parent company and it is always possible to return to the factory settings.

The editable parameters in these two modes are the following:

- Front compression
- Front rebound
- Rear compression
- Rear rebound

Once the parameter to be modified has been highlighted, using the MODE UP / DOWN buttons, it is possible to increase it by one point by briefly pressing the MODE RIGHT button.

Keep the MODE RIGHT button pressed to continuously increase the value until the button is released. Once the maximum setting value has been reached, the count will restart from the minimum value.

With a long press of the MODE SET button, the selected parameter will be reset to the factory value.

The "compression/extension" parameters can be modified from minimum 1 (HARD) to a maximum 31 (SOFT) (one unit corresponds to one click of a traditional suspension).

Briefly press on the MODE SET button to return to the "MGCS" menu

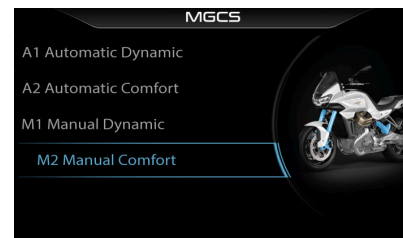

#### 6.2) Automatic dynamic / Automatic comfort

The automatic modes actively adapt the suspension and relative adjustments based

on the vehicle's behaviour in relation with the riding style. Each of the two modes is preset by the parent company and it is always possible to return to the factory settings.

The editable parameters in these two modes are the following:

- Front firmness (front damping)
- Rear firmness (rear damping)
- Brake support (brake assistance)

Once the parameter to be modified has been highlighted, using the MODE UP / DOWN buttons, it is possible to increase it by one point by briefly pressing the MODE RIGHT button.

Keep the MODE RIGHT button pressed to continuously increase the value until the button is released. Once the maximum setting value has been reached, the count will restart from the minimum value.

With a long press of the MODE SET button, the selected parameter will be reset to the factory value.

The values can be modified from a minimum of -5 (SOFT) to a maximum of +5 (HARD).

Briefly press on the MODE SET button to return to the "MGCS" menu.

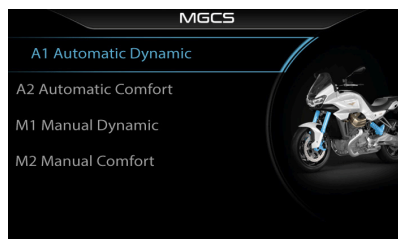

### Cruise Control

**N.B.:**



**ALWAYS SWITCH OFF THE SYSTEM (SWITCHING FROM ON TO OFF) BEFORE CHANGING THE RIDING MODE.**

Cruise control is an electronic system that keeps the vehicle at a constant speed selected by the rider.

Briefly pressing the cruise control selector switch to the left (pressure less than 1 second) starts the system (change from OFF to ON state), the start of the system is indicated by the flashing of the corresponding indicator light on the dashboard.

Going from OFF to ON is also possible with the engine off, as long as the engine stop switch is on RUN.

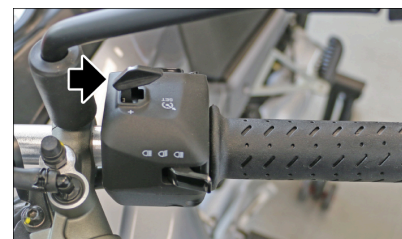

**N.B.:**



**IF THERE IS AN ANTI-THEFT SYSTEM, IT SHOULD BE UNLOCKED TO ALLOW THE SYSTEM TO BE ACTIVATED.**

The system can be used in certain ranges of speeds for the gears from the third to the sixth, even during deceleration and with the throttle grip released.

The maximum and minimum settable speed values depend on the gear currently selected:

- 3rd gear: min. 40 Km/h (25 mph) Max. 90 Km/h (56 mph);
- 4th gear: min. 45 Km/h (28 mph) Max. 110 Km/h (68 mph);
- 5th gear: min. 50 Km/h (31 mph) Max. 130 Km/h (81 mph);
- 6th gear: min. 55 Km/h (34 mph) Max. 180 Km/h (112 mph);

Once at the required speed, the cruise control system may be activated by the rider (switched to SET state) by pushing the cruise control selector briefly (for less than 1 second) to the left, provided that the following conditions are met:

- The engaged gear cannot be less than the third and even in neutral;
- The brakes should not be operated;
- The clutch must not be operated;
- The speed conforms to the limit established for each gear

The indicator lamp on the instrument cluster lights continuously to indicate that the system is active.



The rider may now release the throttle grip, as the system will automatically maintain the set speed.



It is possible to increase or decrease the cruising speed by a short press (less than 1 second) of the cruise control switch up or down (increase / decrease the speed of 2 km/h (1.24 mph)) or via a long press (from 1 to 20 seconds) up or down (increase / decrease in the constant speed). The throttle may be used to increase speed temporarily by up to 30 km / h (18.64 mph) for the third, fourth and fifth gear and 40 km / h (24.85 mph) for the sixth gear with respect to the selected speed without turning off the system (e.g. passing). If the increase in speed exceeds 30 km/h (18.64 mph) for the third, fourth and fifth gear and 40 km/h (24.85 mph) for the sixth gear, it will cause a system deactivation (change from SET to ON, flashing light). Released the throttle grip, the motorcycle will return to the selected cruising speed.



The system is deactivated (change from SET to ON status) if any of the following conditions:

- By operating the clutch;
- Operating the front/rear brake;
- Inserting a lower gear than 3rd or shift into neutral;
- By briefly moving the selector to the left;
- If the engine rpm limiter is activated;
- If the tracking control is activated;
- If climbs or particularly steep descents appear;
- Turning the throttle grip in the direction of contrary rotation

The system can be activated any time observing as usual the previously described conditions and keeping the selector pressed upward (for more than 1 second) if you want to reconfirm the last cruise speed used or by briefly moving the selector to the left to set a new cruising speed.

The system turns off completely (change from SET to the OFF state), then the stored speed is lost and the instrument cluster light

goes off, if any of the following conditions are present:

- Keeping the cruise control selector moved to the left (for more than 1 second);
- Run-off interrupter activated;
- Engine stop (Key-OFF);
- Failure, malfunction of a component involved in controlling the speed (tone wheels sensors, control units, etc.)

#### CAUTION



WHEN ENTERING THE ADJUSTMENT MODE OF THE CRUISE CONTROL, THE QUICK SHIFT SYSTEM IS DISABLED.

#### Adaptive Cruise Control F.C.C - Following Cruise Control

(if applicable)

#### CAUTION



THIS FUNCTION IS ONLY AVAILABLE IF ADAPTIVE CRUISE CONTROL/ FOLLOWING CRUISE CONTROL (F.C.C.) IS INSTALLED IN THE VEHICLE. ADAPTIVE CRUISE

CONTROL / FOLLOWING CRUISE CONTROL (F.C.C) IS A SYSTEM THAT COMBINES CRUISE CONTROL WITH DISTANCE REGULATION. ASSISTS THE DRIVER BY SIMULTANEOUSLY ADJUSTING THE SPEED AND DISTANCE TO THE VEHICLE IN FRONT, BUT WITHIN THE LIMITS OF THE SYSTEM. IF IT DETECTS A VEHICLE IN THE DIRECTION OF TRAVEL, THE SYSTEM CAN SLOW DOWN USING THE ENGINE BRAKE AND THEN ACCELERATE AUTONOMOUSLY. THE PURPOSE OF THE SYSTEM IS TO INCREASE DRIVING COMFORT WHEN DRIVING ON MOTORWAYS.

#### CAUTION



ADAPTIVE CRUISE CONTROL / FOLLOWING CRUISE CONTROL (F.C.C.) IS NEITHER A SAFETY SYSTEM NOR AN OBSTACLE DETECTOR, ITS FUNCTION IS TO IMPROVE THE DRIVER'S DRIVING COMFORT. IS DESIGNED TO ASSIST THE DRIVER, BUT DOES NOT REPLACE THE DRIVER IN DRIVING THE VEHICLE. THE DRIVER HAS A RESPONSIBILITY TO MAINTAIN AT ALL TIMES: CONTROL OF THE VEHICLE, A PRUDENT AND APPROPRIATE SPEED, A SAFE DISTANCE FROM THE VEHICLE IN

FRONT, ALSO IN RELATION TO THE ENVIRONMENTAL CONTEXT, COMPLIANCE WITH THE TRAFFIC REGULATIONS OF THE AREA IN WHICH THEY ARE DRIVING, AS WELL AS ACTIVELY INTERVENING, BY BRAKING OR ACCELERATING, TO AVOID COLLISIONS. THE DRIVER MUST ALWAYS MAINTAIN A HIGH LEVEL OF CONCENTRATION WHILE DRIVING, KEEPING BOTH HANDS ON THE HANDLEBARS AT ALL TIMES.

ADAPTIVE CRUISE CONTROL / FOLLOWING CRUISE CONTROL (F.C.C.) IS DESIGNED FOR USE ON MOTORWAYS OR EXTRA-URBAN ROADS. IS NOT DESIGNED FOR URBAN USE, MOUNTAIN ROADS OR DIRT ROADS. IT IS RECOMMENDED NOT TO USE ADAPTIVE CRUISE CONTROL/ FOLLOWING CRUISE CONTROL (F.C.C.) ON UNEVEN ROADS (GRAVEL OR WET ASPHALT THAT MAY CAUSE RISK OF AQUAPLANING) OR IN ADVERSE WEATHER CONDITIONS (ICE, SNOW, FOG, RAIN, HAIL). IN THESE SITUATIONS, THE ADAPTIVE CRUISE CONTROL/ FOLLOWING CRUISE CONTROL (F.C.C.) DOES NOT PERFORM ITS FUNCTIONS CORRECTLY AND MAY NOT FUNCTION PROPERLY. IT IS ALSO RECOMMENDED NOT TO USE ADAPTIVE CRUISE CONTROL/ FOLLOWING CRUISE CONTROL (F.C.C.) IN COMPLEX ROAD

**SITUATIONS SUCH AS: ROADS CHARACTERISED BY MANY CURVES, BIFURCATIONS, PRESENCE OF ENTRANCE OR EXIT RAMPS, PRESENCE OF ROAD WORKS.**

### **WHAT IS ADAPTIVE CRUISE CONTROL / FOLLOWING CRUISE CONTROL (F.C.C.)**

The vehicle is equipped with two radars: one at the front and one at the rear.

Adaptive Cruise Control uses the information it receives from the front radar (sensor). This type of sensor is subject to operational limitations that are inherent in its technology; therefore the maximum operating speed of the F.C.C. system can be lower than that of the Standard Cruise Control, the deactivation of which is indicated by a dedicated message on the instrument cluster.

In the absence of traffic, the system acts like cruise control, maintaining the set cruising speed. When the vehicle comes close to another vehicle in the same direction of travel, which is detected by the system, the ADAPTIVE / FOLLOWING CRUISE CONTROL (F.C.C.) adapts the vehicle's speed, accelerating or decelerating autonomously (being a comfort system, its acceleration and deceleration capabilities are limited). As soon as the vehicle in front is no longer detected, adaptive cruise control accelerates to the set cruising speed.

### **CAUTION**



**ADAPTIVE CRUISE CONTROL / FOLLOWING CRUISE CONTROL (F.C.C.) IS NOT A SAFETY SYSTEM. ALTHOUGH IT ACCELERATES OR DECELERATES, IT DOES NOT PERFORM EMERGENCY BRAKING: ITS ABILITY TO DECELERATE IS LIMITED. IN CERTAIN SITUATIONS OF THE SURROUNDING ENVIRONMENT OR TRAFFIC, THE SYSTEM MAY REACT BY ACCELERATING OR DECELERATING UNEXPECTEDLY: THE DRIVER MUST THEREFORE ALWAYS RIDE WITH BOTH HANDS ON THE HANDLEBARS TO MAINTAIN MAXIMUM CONTROL OF THE VEHICLE.**

**ADAPTIVE CRUISE CONTROL / FOLLOWING CRUISE CONTROL (F.C.C.) WILL NOT DECELERATE AUTOMATICALLY IF THE DRIVER TURNS THE ACCELERATOR KNOB: THIS WILL EXCLUDE THE ADAPTIVE CRUISE CONTROL/ FOLLOWING CRUISE CONTROL SYSTEM.**

### **CAUTION**



**THE FRONT SURFACE OF THE RADAR MUST NOT BE COVERED WITH DECALS, PAINTED OR OBSTRUCTED IN ANY WAY THAT WOULD PREVENT THE RADAR FROM WORKING PROPERLY. IT IS RECOMMENDED, BEFORE EACH DEPARTURE, TO CHECK THAT THE RADAR FIELD OF VIEW IS CLEAR. THE SAME APPLIES TO ANY MODIFICATION MADE TO THE FRONT OF THE VEHICLE.**



### **CAUTION**



**RADAR HAS A LIMITED FIELD OF VIEW AND TECHNOLOGICAL LIMITATIONS THAT MAY NOT ALLOW THE DETECTION OF VEHICLES AHEAD OF THE MOTORBIKE. IN GENERAL, FOR SOME SCENARIOS, ADAPTIVE CRUISE CONTROL/ FOLLOWING CRUISE CONTROL (F.C.C) MAY RESPOND DIFFERENTLY**

TO WHAT THE DRIVER MIGHT EXPECT. AS AN EXAMPLE, BUT NOT LIMITED TO, THE FOLLOWING IS A LIST OF SOME OF THE LIMITATIONS OF THE SYSTEM:

- THE SYSTEM CANNOT DETECT STATIONARY VEHICLES, IT CAN ONLY DETECT MOVING VEHICLES (SEE SECTION 'STATIONARY VEHICLES');
- THE SYSTEM IS NOT ALWAYS ABLE TO DETECT VEHICLES AHEAD OF THE MOTORBIKE IF THE SPEED DIFFERENCE BETWEEN THE MOTORBIKE AND THESE VEHICLES IS TOO GREAT;
- THE SYSTEM HAS A REDUCED ABILITY TO DETECT VEHICLES CLOSE TO THE MOTORBIKE, ON ITS SIDE OR ENTERING THE ROADWAY. A VEHICLE IN FRONT OF THE MOTORBIKE ENTERING ITS LANE CAN BE DETECTED BY THE SYSTEM IF IT IS IN THE RADAR'S FIELD OF VIEW AND IS CLASSIFIED AS A 'TARGET VEHICLE' BY THE SYSTEM. SIMILARLY, IT MAY HAPPEN THAT THE SYSTEM DOES NOT REACT AS EXPECTED (E.G. ABRUPT DECELERATION, DELAYED DECELERATION, NO DECELERATION);
- ADAPTIVE CRUISE CONTROL MAY DETECT LATE, OR NOT AT ALL, OBJECTS WITH SILHOUETTES

THAT CANNOT BE IDENTIFIED BY THE F.C.C. SYSTEM. WHICH ARE: MOTORBIKES OR VEHICLES WITH A HIGH GROUND CLEARANCE (E.G. TRUCKS), VEHICLES WITH SUSPENDED OR PROTRUDING LOADS, VEHICLES WITH A NARROW CROSS-SECTION OR UNCONVENTIONAL GAUGES. IN SUCH CASES, THE SYSTEM MAY NOT INTERVENE OR MAY INTERVENE INCORRECTLY;

- THE SYSTEM CANNOT DETECT PEDESTRIANS, BICYCLES AND ANIMALS. THE SYSTEM COULD ALSO FAIL TO DETECT PEDESTRIANS, CYCLISTS, PEDESTRIANS PUSHING THEIR BICYCLES, SCOOTERS OR ANY OTHER OBJECT BY HAND;
- THE SYSTEM MAY REACT (E.G. BY DECELERATING) TO SUDDEN DETECTIONS OF SMALL MOVING OBJECTS BEYOND VEHICLES, SUCH AS BALLS, CANS OR METAL CONTAINERS, BAGS, BOXES;
- THE SYSTEM DOES NOT DETECT VEHICLES TRAVELLING IN THE OPPOSITE DIRECTION OR TRANSVERSE TO THE DIRECTION OF TRAVEL OF THE MOTORBIKE;
- THE SYSTEM MAY REACT TO VEHICLES TRAVELLING IN THE LANE ADJACENT TO THAT OF THE MOTORBIKE, CONSEQUENTLY IT MAY UNEXPECTEDLY ACTIVATE DECELERATION; THIS CAN

OCCUR IF TRAVELLING CLOSE TO THE LANE LINES;

- ADAPTIVE CRUISE CONTROL MAY NOT REACT, OR MAY REACT INCORRECTLY, IN THE PRESENCE OF ELECTROMAGNETIC INTERFERENCE OR REFLECTIONS FROM THE SURROUNDING ENVIRONMENT (E.G. IN TUNNELS, IN THE PRESENCE OF GUARDRAILS, HEAVY RAIN, ICE, HAIL OR FOG)
- ADAPTIVE CRUISE CONTROL / FOLLOWING CRUISE CONTROL (F.C.C.) MAY NOT REACT, OR REACT INCORRECTLY, IF THE MOTORBIKE IS TRAVELLING AT AN ANGLE GREATER THAN 20 DEGREES, IN EITHER DIRECTION;
- ADAPTIVE CRUISE CONTROL/ FOLLOWING CRUISE CONTROL (F.C.C.) MAY NOT REACT, OR REACT INCORRECTLY, UNDER CERTAIN ROAD CONDITIONS, INCLUDING BUT NOT LIMITED TO: BRIDGES, TUNNEL ENTRANCES OR EXITS, LARGE OR TEMPORARY ROAD SIGNS;
- ADAPTIVE CRUISE CONTROL/ FOLLOWING CRUISE CONTROL (F.C.C.) MAY NOT REACT, OR REACT INCORRECTLY, IN THE EVENT OF REPEATED BUMPS, JOLTS OR ABRUPT MOVEMENTS OVER TIME THAT COULD CAUSE THE RADAR TO BE

MISALIGNED FROM ITS ORIGINAL POSITION. THIS MISALIGNMENT, IF EXCESSIVE, WILL PREVENT THE SYSTEM FROM WORKING CORRECTLY OR REDUCE ITS EFFECTIVENESS (IN THIS CASE IT IS NECESSARY TO CHECK THE ALIGNMENT AT an official Moto Guzzi dealer). IN THE EVENT OF AN ACCIDENT OR MOTORBIKE FALL, IT IS RECOMMENDED TO HAVE THE RADAR AND ITS POSITIONING EXAMINED BY AN official Moto Guzzi dealer;

- ADAPTIVE CRUISE CONTROL / FOLLOWING CRUISE CONTROL (F.C.C.) MAY NOT REACT, OR REACT INCORRECTLY, IN CERTAIN ENVIRONMENTAL AND/OR TRAFFIC CIRCUMSTANCES IN WHICH RADAR DETECTION MAY BE DISTURBED OR SLOWED DOWN: THIS COULD RESULT IN AN INCORRECT CALCULATION OF THE DISTANCE BETWEEN VEHICLES AND, CONSEQUENTLY, RESULT IN INCORRECT BEHAVIOUR OF THE ADAPTIVE CRUISE CONTROL/ FOLLOWING CRUISE CONTROL (F.C.C.). IN THIS CASE, THE DRIVER MUST ADAPT THE SPEED OF THE MOTORCYCLE TO THE SITUATION AND THE SURROUNDING ENVIRONMENT.

## RADAR BEHAVIOUR IN CURVES

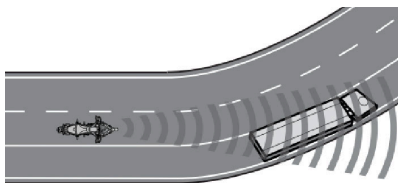

### CAUTION



WHEN ENTERING OR EXITING A CURVE, VEHICLE DETECTION MAY BE DELAYED OR DISTURBED: THE SYSTEM MAY REACT UNEXPECTEDLY WITH SUDDEN ACCELERATION OR DECELERATION.

SIMILAR EVENTS MAY OCCUR MORE IF THE RADIUS OF THE CURVE IS NARROW OR VARIABLE. FOR EXAMPLE, THE VEHICLE IN FRONT MAY BE OUT OF THE RADAR'S FIELD OF VIEW: IN THIS CASE, ADAPTIVE CRUISE CONTROL/ FOLLOWING CRUISE CONTROL (F.C.C.) MAY ACCELERATE WITHOUT THE DRIVER EXPECTING IT.

IN ADDITION, WHEN ENTERING A CURVE, ADAPTIVE CRUISE CONTROL/FOLLOWING CRUISE CONTROL (F.C.C.) MAY REACT, BY

DECELERATING, TO A VEHICLE IN THE ADJACENT LANE.

IT IS ALWAYS POSSIBLE TO PREVENT OR INTERRUPT THESE INTERVENTIONS BY MANUALLY ACTING ON THE ACCELERATOR CONTROL OR THE BRAKES.

## VEHICLE AT A STANDSTILL

### CAUTION



ADAPTIVE CRUISE CONTROL / FOLLOWING CRUISE CONTROL (F.C.C.) CAN ONLY DETECT MOVING VEHICLES. FOR EXAMPLE, IT IS CAPABLE OF RECOGNISING AND REACTING TO A VEHICLE THAT IS STOPPING ( EVEN WITH THE LIMITATIONS SPECIFIED ABOVE), BUT IS NOT CAPABLE OF RECOGNISING AND REACTING TO VEHICLES THAT ARE PARKED OR ALREADY STOPPED ALONG THE ROAD (E.G. VEHICLES STOPPED IN LINE OR QUEUING DUE TO TRAFFIC). IN SUCH CASES, THE DRIVER MUST SLOW DOWN THE MOTORCYCLE BY APPROPRIATELY APPLYING THE BRAKES.

IN GENERAL, THE SYSTEM DOES NOT REACT TO STATIONARY OBJECTS (E.G. TRAFFIC ISLANDS, TOLL BOOTHS) OR STATIONARY

**SUBJECTS (E.G. PEDESTRIANS): THE DRIVER OF THE MOTORCYCLE MUST ALWAYS PAY CLOSE ATTENTION TO THE LIMITS OF THE SYSTEM AND ADAPT HIS OR HER RIDING STYLE TO THE ENVIRONMENTAL SITUATION IN ORDER TO PREVENT ANY DANGER TO PERSONS OR PROPERTY.**

The vehicle also features a radar-based distance-keeping function from the vehicle in front, which **only** acts by adjusting the engine power **WITHOUT INTERVENING THE BRAKE SYSTEM IN ANY WAY.**

#### CAUTION



**THE FCC FUNCTION IS DEPENDENT ON PRIOR ACTIVATION OF THE CRUISE CONTROL AND DOES NOT ALLOW DECELERATION OF THE VEHICLE IF THE CRUISE CONTROL IS NOT IN OPERATION.**

To enable the FCC system, from the main page of the digital display select the relevant page of the travel log by pressing the MODE RIGHT button on the left-hand switch cluster.

Once the page is reached, a short press on the MODE SET (1) button enables the FCC.



**N.B.:**



**ENABLING DOES NOT LEAD TO AN IMMEDIATE ACTIVATION OF THE SYSTEM: ACTUAL OPERATION WILL ONLY TAKE PLACE ONCE CRUISE CONTROL SPEED MAINTENANCE IS ACTIVATED.**

With the system enabled, the MODE UP (2) and MODE DOWN (3) buttons can be used to set the FCC to three levels, which set the distance maintained from the vehicle in front.

- 1 . Minimum distance
- 2 . Intermediate distance
- 3 . Maximum distance

The selected level will be visible in numerical form on the travel log page and, if cruise control is active and thus the FCC is operating, the corresponding graphic illustration (4) below the speedometer will

also be shown and the FCC icon (5) will replace the Cruise Control icon next to the set speed display.

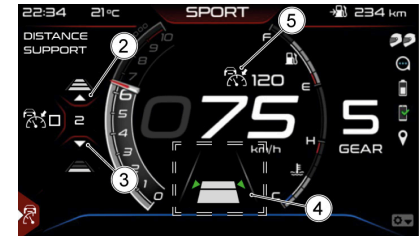

If, with cruise control and the FCC system in operation, the radar detects the presence of a vehicle, which results in an actual reduction in speed by the system, the icon shown in the figure will be added to the graphic illustration below the speedometer to signal the presence of a vehicle ahead.

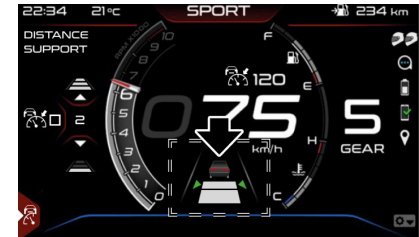

#### CAUTION



THE DISTANCE MAINTAINED IN RELATION TO THE VEHICLE IN FRONT WILL ALWAYS BE CHANGED ACCORDING TO THE SPEED OF TRAVEL. IT IS THEREFORE NORMAL THAT, EVEN AT THE SAME LEVEL, THE DISTANCE MAINTAINED WILL BE GREATER AT HIGHER SPEEDS AND LESS AS THE SPEED REDUCES.

#### CAUTION



THE FCC SYSTEM IMPLEMENTED IN YOUR VEHICLE ONLY ACTS ON THE THROTTLE CONTROL AND DOES NOT ALLOW AUTOMATIC BRAKING OF THE VEHICLE.

THE EFFECTIVENESS OF THE SYSTEM IS THEREFORE CONDITIONED BY THE OPERATING CONTEXT AND UNDER CERTAIN CONDITIONS IT IS NOT POSSIBLE TO AUTOMATICALLY DECELERATE THE VEHICLE OR MAINTAIN A CORRECT DISTANCE FROM THE VEHICLE IN FRONT, FOR EXAMPLE:

- DRIVING DOWNHILL ON A STEEP SLOPE
- DRIVING WITH PASSENGER
- STRONG WIND
- EXCESSIVE SPEED DIFFERENCE TO THE VEHICLE IN FRONT

#### • SUDDEN LANE CHANGES

THE SYSTEM IS TO BE CONSIDERED A DRIVING AID, IT DOES NOT IN ANY WAY REPLACE THE DRIVER, WHO REMAINS SOLELY RESPONSIBLE FOR DRIVING THE VEHICLE. THE DRIVER MUST ALWAYS PAY CLOSE ATTENTION TO TRAFFIC CONDITIONS AND BE READY TO INTERVENE IF NECESSARY, ADHERING TO THE RULES OF THE ROAD AND ENSURING THE CORRECT SAFETY DISTANCE FROM OTHER VEHICLES.

The enable status and distance level set for the FCC **remain stored** even if the vehicle is switched off (Key-OFF); It is therefore not necessary to reset the system every time Cruise Control is activated.

Similarly, it is possible to disable the FCC function at any time by going to the relevant page in the travel log and briefly pressing the MODE SET button, located on the left-hand steering wheel.

#### CAUTION



IF THE FCC SYSTEM IS DEACTIVATED WHILE FOLLOWING A VEHICLE TRAVELLING AT A LOWER SPEED THAN THE SPEED SET BY THE CRUISE CONTROL, THE VEHICLE

WILL START TO ACCELERATE TO THE SPEED SET BY THE CRUISE CONTROL.

SIMILARLY, IT IS POSSIBLE THAT THE RADAR, DUE TO SYSTEM LIMITATIONS (E.G. CORNERING) OR MALFUNCTIONS, LOSES TRACK OF THE VEHICLE BEING FOLLOWED. EVEN IN THESE CASES THE VEHICLE WILL ACCELERATE TO REACH THE SPEED SET BY THE CRUISE CONTROL.

IT IS THE RIDER'S RESPONSIBILITY TO OBSERVE TRAFFIC CONDITIONS AND ACT ACCORDINGLY, FORCING THE MOTORBIKE TO DECELERATE BY REDUCING THE TARGET SPEED OF THE CRUISE CONTROL OR BY BRAKING.

#### GPS navigation

(if applicable)

Combined with the "MOTO GUZZI" application, the "MOTO GUZZI MIA" system allows the display of GPS indications on the digital display. By means of pictograms, distance and travel time data, the desired destination can be reached. The navigation icon appears on the digital display after setting the destination address.

Refer to the navigation guide by accessing the "MOTO GUZZI" application with your account.



N.B.:



BY SETTING THE DESTINATION ADDRESS VIA THE "MOTO GUZZI" APPLICATION, THE DIGITAL DISPLAY AUTOMATICALLY DISPLAYS THE INDICATION SCREEN.

Press and hold down MODE RIGHT to access the GPS navigation directions and information screen.

N.B.:



"SHORT PRESS": PRESS THE BUTTON AND RELEASE WITHIN 0.5 SECONDS;

"PRESS AND HOLD": PRESS THE BUTTON AND HOLD FOR AT LEAST 2 SECONDS.



**Navigation screen legend**

1) Trip log (A / B) / Navigation information (If the Guzzi MIA ECU is present): telephone, music, media player. (Where the components are present): heated seat, heated handgrips;

2) Riding mode selected;  
 3) Clock (displayed in 24 or 12 hour format, without the AM / PM indication);  
 4) Ice hazard icon (displayed at temperatures from -15 °F (5 °C) to +3 °F

(37.4 °C)) / Battery alert indicator (voltage between poles too low);  
 5) Ambient temperature (shown in °F or °C);  
 6) Fuel gauge;

- 7) Indication regarding the manoeuvre after next manoeuvre and the relative distance;
- 8) distance remaining to arrival at destination;
- 9) time remaining to arrive at destination;
- 10) Destination address / Information pop-up;
- 11) indication of the next turn and relative distance;
- 12. Rpm indicator;
- 13) Speed (speedometer) (displayed in km/h or in mph);
- 14) Gear selected (displayed only with engine running and vehicle moving);
- 15) Automatic lights mode active;
- 16) Fog lights active (if applicable)
- 17) Open side stand indicator;
- 18) Water temperature value (displayed in °C or °F);
- 19) Downshift status (where implemented);
- 20) Low tyre pressure alarm;
- 21) Driving in reserve (only when the reserve indicator is on) (displayed in km or mi);
- 22) Indication regarding the speed limit applicable on the current road;
- 23) Suspension failure icon (V100 Mandello S);
- 24) Service icon;

25) Hand grip heating level indicator;

26) Seat heating level indicator;

27) Reduced power map indication (if applicable);.

In the space dedicated to navigation information it is possible to view:

- If not navigating, the list of the last destinations started (if any) is present;
- If navigating, the current destination is present.

## Key switch

### Ignition switch

The ignition switch is on the front of the fuel tank where the steering headstock is.

The vehicle is supplied with two keys (one is the spare key).

The lights can only be switched off with the ignition switch turned to OFF.

**N.B.:**



**THE KEY IS USED IN THE IGNITION/STEERING LOCK SWITCH, THE KEYHOLE FOR THE FUEL TANK CAP, AND FOR THE SADDLE COMPARTMENT.**

**N.B.:**



**THE HEADLIGHTS SWITCH ON AUTOMATICALLY AFTER THE ENGINE STARTS.**

**N.B.:**



**KEEP THE SPARE KEY IN DIFFERENT PLACE, NOT WITH THE VEHICLE.**

**LOCK (1):** The steering is locked. It is not possible to start the engine or switch on the lights. The key can be extracted

**OFF (2):** The engine and lights cannot be set to work. The key can be extracted.

**ON (3):** The engine can be started. The key cannot be extracted.

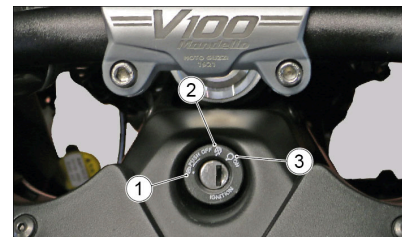

## Engaging the steering lock

### CAUTION



**TO PREVENT THE LOSS OF CONTROL, NEVER TURN THE KEY TO THE "LOCK" POSITION WHILE THE VEHICLE IS RUNNING.**

#### To lock the steering:

- Turn the handlebar fully to the left.
- Turn the key to «OFF».
- Push in the key and turn it anticlockwise (to the left), steer the handlebar slowly until the key is set to «LOCK».
- Extract the key.

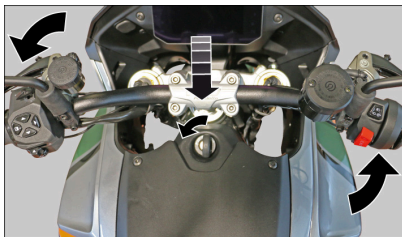

## Horn button

Press it to activate the horn.



## Turn indicator switch

Move the switch to the left to indicate a left turn; move the switch to the right to indicate a right turn. Pressing the switch deactivates the turn indicator.

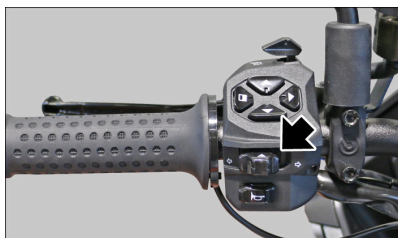

The turn indicators have a self-cancelling function that implements the following logic.

With the vehicle at standstill (speed = zero), the turn indicators continue flashing indefinitely.

With the vehicle in motion, the turn signals self-cancel when one of the two following conditions is met:

- After a time (t) = 40 sec.

- After riding 500 m (0.31 mi)

If the vehicle speed reaches zero during this period, the time and distance counts are reset and start again from zero when the vehicle starts moving once again.

Switching on the opposite side turn indicators without pressing the switch in the intermediate reset position causes both the time and distance counters to reset and recommence from zero.

## Light switch

In DRL ON mode:

- the DRL lights only are lit when the selector is left in the centre position (2).
- pressing the selector into position (1) switches on the high beam headlight
- press the selector into position (3) to flash the high beam headlamp to signal danger or an emergency.

When the low beam headlights are on (DRL OFF):

- the low beam lights only are lit when the selector is left in the centre position (2).
- pressing the selector into position (1) switches on the high beam headlight.
- press the selector into position (3) to flash the high beam headlamp to signal danger or an emergency.

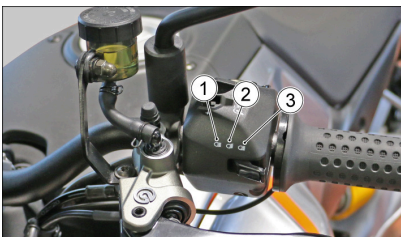

## High beam flash switch

Press button (3) to flash the high beam headlamp to signal danger or an emergency.

Releasing the switch deactivates the high beam flash.

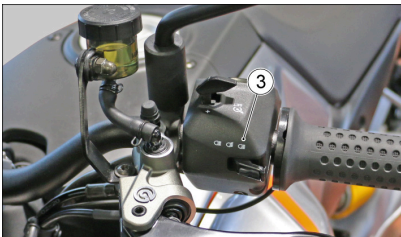

## Daytime/night lights switch

This button allows to select the use mode of the daytime running lights (DRL), night lights (low / high beams) and the activation of the fog lights (if applicable).



- Press the button briefly to cycle through the modes available (daytime/night-time lights).
- A long press of the button will activate the fog lights regardless of the lighting mode active.
- A further long press will deactivate the fog lights.

**N.B.:**



**IF THE "HEADLAMP MODE" FUNCTION (SEE SECTION "ADVANCED FUNCTIONS") IS SET TO "AUTO" (AUTOMATIC), THE TWILIGHT SENSOR IS ALSO USED TO SWITCH THE LOW BEAM HEADLIGHTS ON AUTOMATICALLY IN LOW LIGHT CONDITIONS.**

**IF THE "HEADLAMP MODE" FUNCTION IS SET TO "EMERGENCY", THE DAYTIME RUNNING LIGHTS (DRL) ARE DISABLED AND THE LOW**

**BEAM HEADLIGHTS ONLY REMAIN PERMANENTLY LIT.**

**N.B.:**



**THE FOG LIGHTS WILL BE DEACTIVATED WITH EACH KEY OFF/ON. THE LOW/HIGH BEAM LIGHTS ARE ONLY ON WHEN THE ENGINE IS RUNNING.**

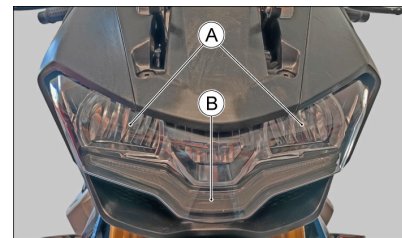

**N.B.:**



**WHEN THE LOW BEAM HEADLIGHTS ARE ON (A), THE BRIGHTNESS OF THE DRL LIGHTS (B) IS DIMMED.**

**N.B.:**



**FLASHING OF THE FOG LIGHTS ICON ON THE DIGITAL DISPLAY INDICATES A PROBLEM WITH THE FRONT LIGHT CLUSTER. CONTACT AN official Moto Guzzi dealer AS SOON AS POSSIBLE.**

## Heated handgrip control

(if applicable)

The activation, deactivation and heat level of the heated hand grips is performed with the control button.

The page dedicated to setting the heated grips can be viewed by scrolling through the pages in the space dedicated to the trip log.

Once the heated knobs page is reached, you can activate them by briefly pressing the MODE UP button and then, with further presses, increase the level of heat intensity.



**N.B.:**



**HEATING OF THE HAND GRIPS, REGARDLESS OF THE INTENSITY LEVEL CHOSEN, ONLY OCCURS WITH THE ENGINE STARTED AND OVER 2000 rpm.**

By briefly pressing the MODE DOWN button, the heat intensity level can be lowered until the system is switched off ('OFF' state).



When knob heating is activated, the corresponding icon on the dashboard is activated, which also shows the selected heating intensity level.

### WARNING



**THE FLASHING SYMBOL INDICATES THE MALFUNCTION OF A GRIP.**

**N.B.:**



**THE HEATED GRIPS ARE OFF WITH EACH KEY OFF-ON.**

## Heated saddle command

(if applicable)

The heated saddle is switched on, off and the heat level is set using the control buttons.

The page dedicated to setting the heated saddle can be viewed by scrolling through the pages in the space dedicated to the trip log.

By briefly pressing the MODE UP button it is possible to activate the heating and subsequently with further presses to increase the heat intensity level.

By briefly pressing the MODE DOWN button it is possible to lower the intensity level and subsequently deactivate the system.



**N.B.:**

**HEATING OF THE SADDLE, REGARDLESS OF THE INTENSITY LEVEL CHOSEN, ONLY OCCURS WITH THE ENGINE STARTED AND OVER 2000 rpm.**

**N.B.:**

**EACH OFF-ON KEY SWITCHES THE SADDLE HEATING OFF.**

**WARNING**

**THE FLASHING SYMBOL INDICATES THE MALFUNCTION OF THE HEATING SYSTEM.**

## Starter button

By pressing the button on the right side handlebar, the starter motor spins the engine.

The following conditions are necessary to permit engine start:

- If the vehicle is in neutral with the side stand extended: Press the starter button on the right side handlebar.
- If the vehicle has any gear is engaged and the stand is closed: Pull the clutch lever and at the same time press the starter button on the right side handlebar.

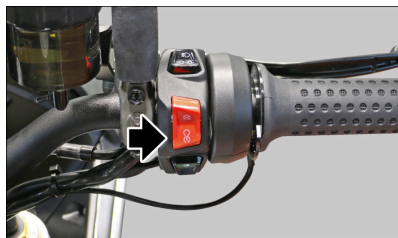

## Engine stop switch

It acts as a safety or emergency switch.

Press and hold the ignition switch in the "KEY ON" position to start the engine; press the switch to set it to "KEY OFF" to stop the engine.

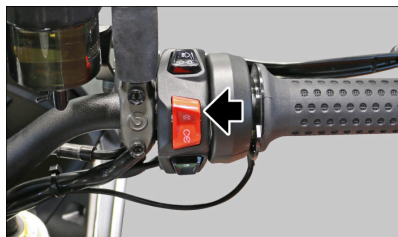
**N.B.:**

**WITH ENGINE OFF AND THE IGNITION SWITCH SET TO «ON» THE BATTERY MAY DISCHARGE.**

## The Immobilizer system

### The Immobilizer system function

For enhanced theft protection, the vehicle is equipped with an electronic immobilizer system that is activated automatically when the ignition key is removed.

Keep the second key in a safe place since it is not possible to make a copy if it gets lost. This would imply replacing numerous parts of the vehicle (besides the locks).

Each key in the grip has an electronic device - transponder - which modulates the radio frequency signal emitted by a special aerial inside the switch when the vehicle is started.

The modulated signal is the "password" by which the appropriate central unit recognises the key and only after this occurs, it allows the engine start-up.

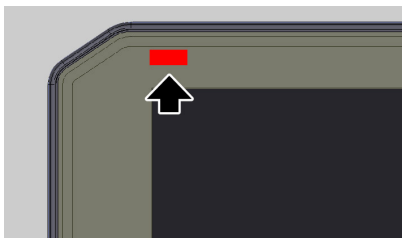
**N.B.:**

**THE IMMOBILIZER SYSTEM CAN MEMORISE UP TO FOUR KEYS.**

**DATA STORAGE OPERATION CAN ONLY BE PERFORMED AT AN Authorised Moto Guzzi Dealer**

**DATA STORAGE PROCEDURE CANCELS THE EXISTING CODES. THEREFORE, IF A CUSTOMER WANTS TO PROGRAM SOME NEW KEYS, S/ HE SHOULD GO TO THE DEALER TAKING ALL THE KEYS S/HE WANTS TO ENABLE.**

In the event the instrument panel detects a fault with the immobilizer system when the key is connected, you will need to enter the user code to start the motorcycle. At the same time the indicator light appears on the instrument panel, the general red warning light will come on.



Once the code has been correctly entered, the identified error will be displayed on the screen. It is then possible to start the motorcycle so you can go immediately to an Authorised **Moto Guzzi Dealer**.

**N.B.:**

**PRESSING OR MOVING ANY CONTROL ON THE LEFT SWITCH CLUSTER, IT IS POSSIBLE TO REMOVE THE ERROR NOTIFICATION SCREEN, BUT THE SCREEN WILL BE**

**VISIBLE AGAIN AFTER ABOUT 10 SECONDS.**

## The saddle

### Saddle opening

- Rest the vehicle on its stand.
- Insert the key in the saddle lock located on the left-hand side fairing.
- Turn the key clockwise to release the passenger saddle from the lock.



- Lift the front part of the passenger saddle and bring it toward the rear of the vehicle to remove it.
- Now it is possible to access the storage compartment of the vehicle.



- Lift the rear part of the rider saddle, bring it toward the rear of the vehicle to release it from the relative supports and then remove it from the vehicle.
- Once the driver and passenger saddles are removed, you will have access to the vehicle's battery.

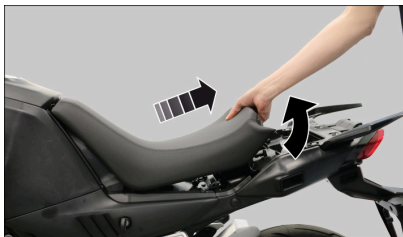

#### Refitting the saddles:

- Move the rider saddle rider in its position, taking care to insert the central fastener and the two front fasteners in the relative seats.



- Insert the rear fastener of the passenger saddle in its support on the vehicle.
- Keeping the saddle in position, press downward the front part to engage the lock.



#### WARNING



**BEFORE LOWERING AND LOCKING THE SADDLE, MAKE SURE THAT THE IGNITION KEY HAS NOT BEEN FORGOTTEN IN AN UNSUITABLE POSITION UNDER THE SADDLE.**

#### CAUTION



**BEFORE SETTING OFF, MAKE SURE THAT THE SADDLE IS CORRECTLY LOCKED INTO POSITION.**

#### Document / tool kit compartment

To access the glove / tool kit compartment it is necessary to remove the passenger seat, using the relevant lock on the left side of the vehicle.

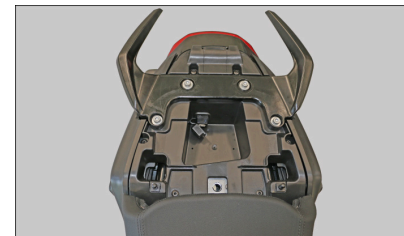

#### USB port

The vehicle is equipped with a USB port, located in the storage compartment under the passenger saddle.

To use it, remove the protection cap from the port. To prevent damage to the port, put the protective cap whenever the port is not in use.

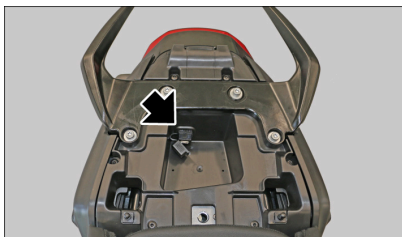

**WARNING**



**IF A USB DEVICE IS CONNECTED, ENSURE THE CORRECT POSITIONING OF THE CABLE TO AVOID THAT IT WILL BE SMASHED.**

**Additional USB port (if provided)**

The additional USB port (if installed) is located next to the dashboard on the left side of the top fairing.

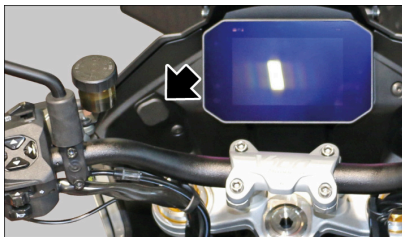

**WARNING**



**TO PREVENT WATER AND/OR HUMIDITY FROM DAMAGING THE USB PORT, DO NOT CONNECT ANY DEVICES IN CASE OF RAIN.**

**WARNING**



**IF A USB DEVICE IS CONNECTED, ENSURE THE CORRECT POSITIONING OF THE CABLE TO AVOID THAT IT WILL BE SMASHED.**

The USB ports are activated when the key is turned to the "ON" position.

**USB port**

Output voltage (5.00+/-0.25) dc

Charge current 1A Max

**WARNING**



**PROLONGED USE OF THE USB PORT MAY PARTIALLY DRAIN THE BATTERY.**

**Identification**

Write down the chassis and engine number in the specific space in this booklet. The chassis number is handy when purchasing spare parts.

**WARNING**



**THE MODIFICATION OF THE IDENTIFICATION CODES IS A SERIOUS PUNISHABLE CRIME. HOWEVER, THE LIMITED WARRANTY FOR NEW VEHICLES WILL BE VOID IF THE VEHICLE IDENTIFICATION NUMBER (VIN) HAS BEEN MODIFIED OR NOT PROMPTLY DETERMINED.**

**FRAME NUMBER**

The chassis number is stamped on the RH side of the headstock.

Chassis No. ....

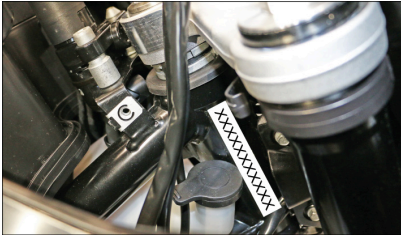

### ENGINE NUMBER

The engine number is stamped on the left side of the crankcase, under the cylinder.

Engine No. ....

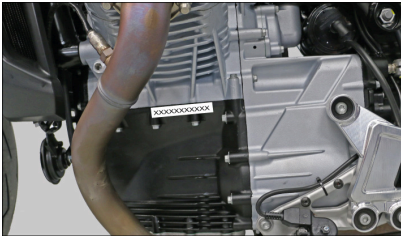

### Windshield adjustment

The windshield height can be adjusted electronically by selecting "WINDSCREEN REGULATION" using the "MODE SET" button on the left-hand switch. The height can then be adjusted using the MODE UP and MODE DOWN buttons on the left-hand switch.



### WARNING



**IN THE EVENT THAT MOVEMENT OF THE WINDSCREEN IS SLOWED DOWN AND/OR DIFFICULT, LUBRICATE THE JOINTS OF THE ADJUSTABLE WINDSCREEN SUPPORT WITH MULTI-PURPOSE SPRAY LUBRICANT.**



# V100 Mandello - V100 Mandello S



**CHAPTER 03**  
**Use**

## Controls

### CAUTION



**BEFORE DEPARTURE, ALWAYS CARRY OUT A PRELIMINARY CHECK OF THE VEHICLE, FOR CORRECT AND SAFE OPERATION. FAILURE TO DO SO MAY CAUSE SEVERE PERSONAL INJURY OR VEHICLE DAMAGE.**

**DO NOT HESITATE TO CONTACT AN Official Moto Guzzi Dealer IF YOU DO NOT UNDERSTAND HOW SOME CONTROLS WORK OR IF MALFUNCTIONING IS DETECTED OR SUSPECTED.**

**CHECKS DO NOT TAKE LONG AND RESULT IN SIGNIFICANTLY ENHANCED SAFETY.**

This vehicle has been programmed to indicate in real time any operation failure stored in the electronic control unit memory.

Whenever the ignition switch is set to "ON", the Pop-Up area of the dashboard will turn red and the general warning icon will be displayed.



### Pre-ride checks

**Front and rear disc brake** Check for proper operation. Check brake lever empty travel and brake fluid level. Check for leaks. Check brake pads for wear. If necessary top-up with brake fluid.

**Throttle grip** Check that the rotation is smooth in both directions and that there is no jamming.

**Engine oil** Check and/or top-up as required.

**Coolant** Check and/or top-up as required.

**Wheels/ tyres** Check that tyres are in good conditions. Check

### Pre-ride checks

inflation pressure, tyre wear and potential damage.

Remove any possible strange body that might be stuck in the tread design.

**Brake levers** Check they function smoothly.  
Lubricate the joints and adjust the travel if necessary.

**Clutch lever** Check correct operation and empty travel. Lubricate the joints if necessary.

**Steering** Check that the rotation is uniform, smooth and there are no signs of clearance or slackness.

Pre-ride checks	
Side stand	Check that it slides smoothly and that it snaps back to its rest position upon spring tension. Lubricate couplings and joints if necessary.
Clamping elements	Check that the clamping elements are not loose.  Adjust or tighten them as required.
Fuel tank	Check level and refill if necessary.  Check the circuit for leaks or obstructions.  Check that the tank cap closes correctly.
Engine stop switch (ON - OFF)	Check function.
Lights, warning lights, horn and electrical devices	Check function of horn and lights.
Tone wheel	Check the front tone wheel for

Pre-ride checks
cleanliness and damage.

## Refuelling

### CAUTION



**THE FUEL IS EXTREMELY INFLAMMABLE AND MAY BECOME EXPLOSIVE IN CERTAIN CONDITIONS.**

**FOR THIS REASON, IT IS NECESSARY TO REFUEL THE VEHICLE AND PERFORM MAINTENANCE OPERATIONS INVOLVING THE FUEL SYSTEM IN A WELL VENTILATED AREA, WITH THE ENGINE SWITCHED OFF.**

**DO NOT REFUEL AND DO NOT PERFORM MAINTENANCE OPERATIONS WITH THE ENGINE RUNNING.**

**DO NOT SMOKE WHILE REFUELING OR IN PROXIMITY TO DANGEROUS FUMES. NEVER ALLOW THE FUEL TO COME INTO CONTACT WITH FLAMES, SPARKS OR HEAT SOURCES. TRY TO CAREFULLY AVOID FUEL SPILLAGE WHILE REFUELING. FUEL SPLASHES MAY IGNITE IF THEY COME INTO CONTACT WITH THE HOT ENGINE**

**OR WITH THE EXHAUST SYSTEM SURFACES. IN CASE OF ACCIDENTAL FUEL SPILLAGE, MAKE SURE THAT THE FUEL HAS COMPLETELY DRIED OUT OR EVAPORATED BEFORE STARTING THE VEHICLE.**

**AVOID THE FUEL COMING INTO CONTACT WITH YOUR SKIN AND AVOID INHALING THE FUMES EMITTED BY THE FUEL.**

**NEVER ATTEMPT TO TRANSFER FUEL FROM ONE CONTAINER TO ANOTHER USING YOUR MOUTH AS TRANSFER MEANS. USE A MANUAL PUMP OR A SIMILAR TOOL.**

### CAUTION



**THE FUEL IS POISONOUS AND CARCINOGENIC AND CONTAINS CHEMICALS THAT CAUSE IMPAIRMENTS AND SEVERAL BIRTH PROBLEMS.**

**IF YOU ACCIDENTALLY SPILL FUEL ON THE SKIN OR CLOTHES, CLEAN IMMEDIATELY WITH WATER AND SOAP AND CHANGE CLOTHES.**

**IF THE FUEL ACCIDENTALLY COMES INTO CONTACT WITH YOUR EYES, RINSE THEM WITH PLENTY OF WATER AND IMMEDIATELY SEEK MEDICAL ATTENTION. IF YOU ACCIDENTALLY**

INGEST FUEL, DO NOT INDUCE VOMITING. DRINK A LARGE AMOUNT OF MILK OR WATER AND CONTACT A DOCTOR AS SOON AS POSSIBLE.

IF YOUR VEHICLE TIPS OVER, IT WILL LOSE FUEL, WHICH IS EXTREMELY INFLAMMABLE. FLAMES AND SPARKS MAY RESULT IN SERIOUS FIRES THAT WILL NOT ONLY DESTROY YOUR VEHICLE, BUT WILL ALSO BE EXTREMELY DANGEROUS FOR THE SURROUNDING VEHICLES AND BUILDINGS, WHICH MAY CAUSE VERY SERIOUS INJURIES AND EVEN DEATH.

ALWAYS KEEP THE FUEL AWAY FROM CHILDREN. DISPOSE OF CORRECTLY; DO NOT DRAIN IT INTO THE SEWAGE SYSTEM OR AT THE BATHROOM.

**Fuel:** Unleaded gasoline E10 (95 R.O.N.)

To refuel:

- Lift the cover (1).
- Introduce the key (2) in the fuel tank cap lock.
- Turn the key clockwise, pull and open the fuel filler cap (3).

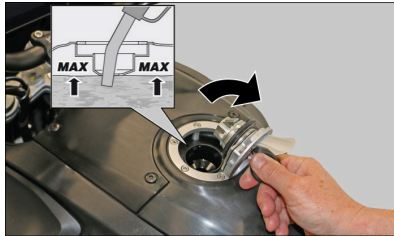

#### WARNING



ALWAYS USE PETROL WITH A MAXIMUM OF 10% BIOETHANOL CONTENT (E10).

DO NOT USE FUEL WITH ETHANOL CONTENT OF MORE THAN 10%. SUCH USE COULD DAMAGE THE SUPPLY SYSTEM COMPONENTS AND/OR AFFECT THE ENGINE OPERATION.

**Fuel tank (including reserve)** 17 l (3.74 UK gal; 4.49 US gal)

**Fuel tank reserve** 3.5 +/- 0.5 l (0.77 +/- 0.11 UK gal; 0.92 +/- 0.13 US gal)

#### N.B.:



NEVER COMPLETELY TOP-UP THE RESERVOIR; THE MAXIMUM FUEL LEVEL MUST REMAIN BELOW THE LOWER EDGE OF THE SUMP (SEE FIGURE).

- Refill.

#### WARNING



DO NOT ADD ADDITIVES OR ANY OTHER SUBSTANCES TO THE FUEL. WHEN USING A FUNNEL, ENSURE THAT IT IS PERFECTLY CLEAN.

#### CAUTION



DURING REFUELLING AVOID FUEL LEAKAGES, WHICH MAY CAUSE DAMAGE TO THINGS OR PERSONS AND FIRE HAZARD.

#### CAUTION



**WHILE REFUELLING, DO NOT USE ELECTRONIC DEVICES AND/OR CELLULAR PHONES THAT COULD CAUSE DAMAGE TO THINGS AND/OR PEOPLE DUE TO GASOLINE VAPOURS.**

#### After refuelling:

- The cap can only be closed if the key (2) is inserted.
- Once the key (2) is inserted, press the cap against the tank to close it again.
- Remove the key (2).
- Close the cover (1).

#### CAUTION



**MAKE SURE THE CAP IS TIGHTLY CLOSED.**

## Adjusting the rear shock absorbers

The shock absorber, in both "V100 Mandello" and "V100 Mandello S" versions, has an external adjuster (1) for adjusting the spring pre-load.

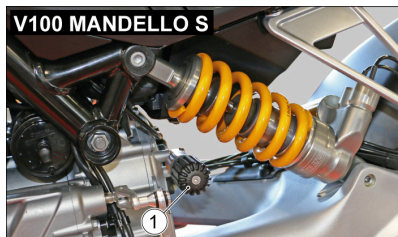
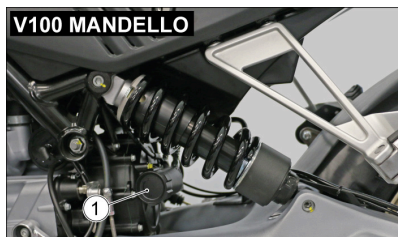

**N.B.:**



**IT IS POSSIBLE TO VARY THE PRE-LOAD OF THE SHOCK ABSORBER DEPENDING ON THE LOAD ON THE VEHICLE (PASSENGER OR HEAVY LOAD).**

**WARNING**



**DO NOT FORCE THE ROTATION OF THE ADJUSTMENT SCREW BEYOND THE LIMIT STOP IN BOTH DIRECTIONS, IN ORDER TO PREVENT ANY DAMAGE.**

On the upper part of the shock absorber, only for "V100 Mandello", there is an adjuster ( 2) to adjust the rebound hydraulic braking. Instead, the shock absorber settings on "V100 Mandello S" are electronically adjusted and can be adjusted via the instrument panel. For more information, refer to "ADVANCED FUNCTIONS" in the "VEHICLE" chapter.

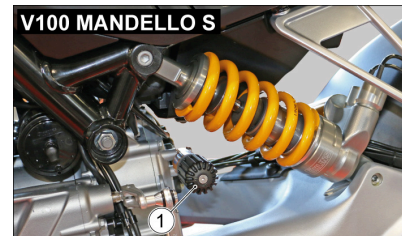

**WARNING**



**DO NOT FORCE THE ROTATION OF THE ADJUSTMENT SCREW BEYOND THE LIMIT STOP IN BOTH DIRECTIONS, IN ORDER TO PREVENT ANY DAMAGE.**

### Spring pre-load

By adjusting the spring pre-load, the seat of the spring itself is moved. Carrying out the adjustment, you can decrease or increase the stiffness of the spring and therefore lower or raise the height of the rear of the vehicle. The spring pre-load is essential for the function performed by the rear shock absorbers. If the spring pre-load is not adjusted correctly, no other adjustment will be effective to obtain good shock absorber performance.

### Rebound braking

Rebound braking controls the energy absorption when the shock absorber is in the rebound phase. In other words, rebound braking adjusts the speed at which the shock absorber returns to the normal position after having been compressed.

#### CAUTION



**SET SPRING PRE-LOADING AND SHOCK ABSORBER REBOUND DAMPING ACCORDING TO THE VEHICLE USE CONDITIONS.**

**IF THE SPRING PRE-LOADING IS INCREASED, IT IS NECESSARY TO INCREASE THE REBOUND DAMPING ACCORDINGLY TO AVOID SUDDEN JERKS WHEN RIDING.**

#### CAUTION



**ALWAYS OBSERVE THE RECOMMENDED ADJUSTMENT RANGE.**

**FOR THE CORRECT SETTING PARAMETERS, READ THE SECTION "SETTING THE REAR SHOCK ABSORBERS" CAREFULLY.**

**IF NECESSARY, CONTACT AN Official Moto Guzzi Dealer.**

### Rear shock absorbers setting

#### V100 MANDELLO

#### Spring pre-load adjustment

To adjust the spring pre-load, turn the adjuster knob (1) clockwise to increase the pre-load or counterclockwise to decrease it.

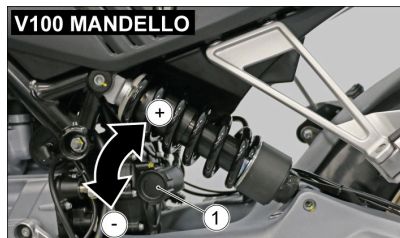

#### WARNING



**DO NOT FORCE THE ROTATION OF THE ADJUSTMENT SCREW BEYOND THE LIMIT STOP IN BOTH DIRECTIONS, IN ORDER TO PREVENT ANY DAMAGE.**

**N.B.:**



**AS THE PRE-LOAD INCREASES, THE SPRING LENGTH WILL DECREASE, AND VICE VERSA IF THE PRE-LOAD DECREASES, THE SPRING LENGTH WILL INCREASE.**

#### Rebound braking adjustment

To adjust the rebound (return) braking, use a flat-head screwdriver to turn the adjuster (2) located at the top of the shock absorber.

Turn the adjuster clockwise to increase braking, or counter-clockwise to decrease braking.

#### WARNING



**DO NOT FORCE THE ROTATION OF THE ADJUSTMENT SCREW**

**BEYOND THE LIMIT STOP IN BOTH DIRECTIONS, IN ORDER TO PREVENT ANY DAMAGE.**

Follow the instructions in the tables below for the optimal setting of the vehicle according to the conditions of use.

**RECOMMENDED SETTING V100 MANDELLO**

**RIDER ONLY**

- PRE-LOAD (KNOB) - FROM FULLY OPEN (\*\*) CLOSE (\*): 1 snap
- HYDRAULIC BRAKING (ADJUSTER) - FROM FULLY CLOSED (\*) OPEN (\*\*): 2 turns

**RIDER + BAGS AND TOP CASE OR RIDER + PASSENGER**

- PRE-LOAD (KNOB) - FROM FULLY OPEN (\*\*) CLOSE (\*): 22 clicks
- HYDRAULIC BRAKING (ADJUSTER) - FROM FULLY CLOSED (\*) OPEN (\*\*): 1 turn

**RIDER + PASSENGER + LUGGAGE**

- PRE-LOAD (KNOB) - FROM FULLY OPEN (\*\*) CLOSE (\*): 26 clicks
- HYDRAULIC BRAKING (ADJUSTER) - FROM FULLY CLOSED (\*) OPEN (\*\*): 1 turn

(\*) = clockwise

(\*\*) = anticlockwise

**CAUTION**



**IN CASE OF UNEVEN ROAD SURFACES, WITH THE PRESENCE OF POTHoles AND/OR DEPRESSIONS, THE "RIDER + PASSENGER + LUGGAGE" SETTING IS RECOMMENDED.**

**V 100 MANDELLO S**

**Spring pre-load adjustment**

To adjust the spring pre-load, turn the adjuster knob (1) clockwise to increase the pre-load or counterclockwise to decrease it.

**WARNING**



**DO NOT FORCE THE ROTATION OF THE ADJUSTMENT SCREW BEYOND THE LIMIT STOP IN BOTH DIRECTIONS, IN ORDER TO PREVENT ANY DAMAGE.**

**N.B.:**



**AS THE PRE-LOAD INCREASES, THE SPRING LENGTH WILL DECREASE, AND VICE VERSA IF THE PRE-LOAD DECREASES, THE SPRING LENGTH WILL INCREASE.**

**V100 MANDELLO S**

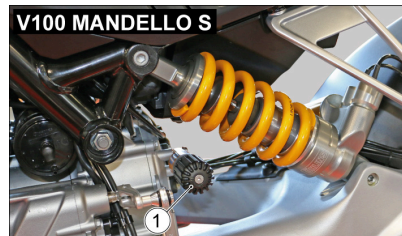

**RECOMMENDED SETTING V100 MANDELLO S**

**RIDER ONLY**

- PRE-LOAD (KNOB) - FROM FULLY OPEN (\*\*) CLOSE (\*): 4 turns

**RIDER + BAGS AND TOP CASE OR RIDER + PASSENGER**

- PRE-LOAD (KNOB) - FROM FULLY OPEN (\*\*) CLOSE (\*): 12 turns

**RIDER + PASSENGER + LUGGAGE**

- PRE-LOAD (KNOB) - FROM FULLY OPEN (\*\*) CLOSE (\*): 16 turns

(\*) = clockwise

(\*\*) = anticlockwise

**CAUTION**



IN CASE OF UNEVEN ROAD SURFACES, WITH THE PRESENCE OF POTHOLES AND/OR DEPRESSIONS, THE "RIDER + PASSENGER + LUGGAGE" SETTING IS RECOMMENDED.

#### "SPORT" setting:

- MGCS mode: A1 - Dynamic

#### "ROAD" Setting:

- MGCS mode: A2 - Comfort

#### "TOURING" Setting:

- MGCS mode: A1 - Dynamic

#### "RAIN" setting:

- MGCS mode: A2 - Comfort

The pre-load of the rear shock absorber depends on the load on the vehicle, **NOT** on the "Riding Mode" used. Therefore, always refer to the "RECOMMENDED settings" table above for pre-load adjustment.

#### CAUTION



ALL MODES CAN BE EDITED BY THE USER AND IT IS ALWAYS POSSIBLE TO RETURN EACH MODE TO THE FACTORY SETTINGS, AS EXPLAINED

IN THE "ADVANCED FUNCTIONS" PARAGRAPH.

IF YOU WANT TO CHANGE THE FACTORY SETTINGS, TEST THE VEHICLE REPEATEDLY UNTIL THE OPTIMUM ADJUSTMENT IS OBTAINED.

IF NECESSARY, CONTACT AN Official Moto Guzzi Dealer.

## Front fork adjustment

Operating the front brake lever, press the handlebar repeatedly to send the fork fully down. The shock absorber should compress and extend smoothly with no signs of oil leakage on the stanchions.

Check the tightening of all the elements and the correct operation of the front and rear suspension joints.



#### WARNING



TO HAVE THE FRONT FORK OIL AND OIL SEALS REPLACED, CONTACT AN Official Moto Guzzi Dealer.

### V 100 MANDELLO

The front suspension consists of a hydraulic fork connected to the headstock by means of two plates.

The right stem of the fork has an upper nut (2) for adjusting the spring pre-load and an upper adjustment screw (1) for adjusting the hydraulic braking in rebound.

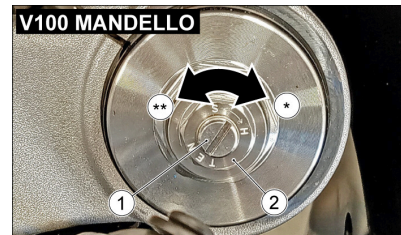

#### WARNING



DO NOT FORCE THE ROTATION OF THE ADJUSTMENT SCREW BEYOND THE LIMIT STOP IN BOTH DIRECTIONS, IN ORDER TO PREVENT ANY DAMAGE.

#### WARNING



**WHEN SPRING PRE-LOAD IS INCREASED, REBOUND DAMPING MUST ALSO BE INCREASED TO PREVENT EXCESSIVE SUSPENSION KICKBACK WHEN RIDING.**

The standard front fork setting is adjusted to suit most high and low speed riding conditions, whether the vehicle is partially or fully loaded.

However, the setting can be modified for specific needs according to vehicle use.

**CAUTION**



**FOR THE CORRECT SETTING PARAMETERS, READ THE SECTION "SETTING THE FRONT FORK" CAREFULLY.**

**IF NECESSARY, CONTACT AN Official Moto Guzzi Dealer.**

**V 100 MANDELLO S**

The spring pre-load is adjusted by the manufacturer to suit any riding type; therefore, even if possible, it is strongly advised not to change the adjustment.

- To adjust the spring pre-load, it is necessary to disconnect the connector (1) from the stem plug, so as not to twist the wiring harness during the adjustment operations.

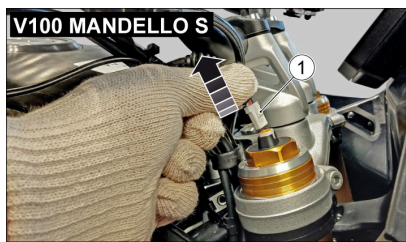

**WARNING**



**TO AVOID DAMAGING THE CONNECTOR, PRESS THE TAB (2) ON THE INDICATED POINT AND THEN CAREFULLY REMOVE THE CONNECTOR.**

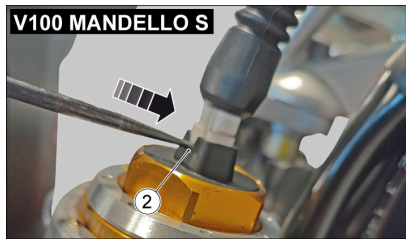

**WARNING**



**PAY SPECIFIC ATTENTION WHEN DISCONNECTING THE CONNECTORS, TO AVOID DAMAGING THEM, WHICH WOULD COMPROMISE THE OPERATION OF THE VEHICLE.**

- Using a spanner, turn the adjusting nut (3) clockwise to increase the pre-load or anti-clockwise to decrease it.
- Repeat the adjustment operations for the second stem, taking care to adjust both stems equally.

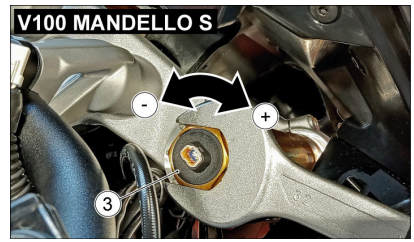

**CAUTION**



**SET THE SPRING PRE-LOADING AND THE EXTENSION HYDRAULIC BRAKING OF THE FRONT FORK**

**ACCORDING TO THE VEHICLE USE CONDITIONS.**

**BY INCREASING THE SPRING PRE-LOAD, THE CONTROL PARAMETERS OF THE FRONT FORK MUST BE ADJUSTED (BY INCREASING THEIR VALUES) TO AVOID UNEXPECTED JOLTS WHILE DRIVING.**

The "V 100 Mandello S" fork adjustments are performed electronically; these settings can be adjusted via the instrument panel. For more information, refer to "ADVANCED FUNCTIONS" in the "VEHICLE" chapter.

### Setting the front fork

#### V 100 MANDELLO

#### WARNING



**TO COUNT THE NUMBER OF CLICKS OF THE ADJUSTER (1) ALWAYS START FROM THE MOST RIGID SETTING (COMPLETE CLOCKWISE ROTATION).**

**TO PREVENT DAMAGE TO THE ADJUSTER SCREWS (1), NEVER FORCE THEM BEYOND THE END OF TRAVEL IN EITHER DIRECTION.**

#### RECOMMENDED SETTING V100 MANDELLO

##### RIDER ONLY

- PRE-LOAD (NUT) - FROM COMPLETELY OPEN (\*\*) CLOSE (\*): 6 turns
- HYDRAULIC BRAKING (ADJUSTER) - FROM FULLY CLOSED (\*) OPEN (\*\*): 6 clicks
- STANCHION PROTRUSION (A) (\*\*\*) FROM UPPER PLATE (EXCLUDING CAP): 1 Notch (5mm - 0.20 in)

##### RIDER + BAGS AND TOP CASE OR RIDER + PASSENGER

- PRE-LOAD (NUT) - FROM COMPLETELY OPEN (\*\*) CLOSE (\*): 6 turns
- HYDRAULIC BRAKING (ADJUSTER) - FROM FULLY CLOSED (\*) OPEN (\*\*): 6 clicks
- STANCHION PROTRUSION (A) (\*\*\*) FROM UPPER PLATE (EXCLUDING CAP): 1 Notch (5mm - 0.20 in)

##### RIDER + PASSENGER + LUGGAGE

- PRE-LOAD (NUT) - FROM COMPLETELY OPEN (\*\*) CLOSE (\*): 6 turns
- HYDRAULIC BRAKING (ADJUSTER) - FROM FULLY CLOSED (\*) OPEN (\*\*): 6 clicks
- STANCHION PROTRUSION (A) (\*\*\*) FROM UPPER PLATE (EXCLUDING CAP): 1 Notch (5mm - 0.20 in)

(\*) = clockwise

(\*\*) = anticlockwise

(\*\*\*) - this type of adjustment may only be made by an Authorised Moto Guzzi Dealer.

#### V 100 MANDELLO S

The factory settings of the MGCS system are as follows:

##### "SPORT" setting:

- Spring pre-load (3): From fully open, 8 turns clockwise
- MGCS mode: A1 - Dynamic
- Stanchion protrusion (A) (\*\*\*) : 1 notch (4 mm - 0.16 in)

##### "ROAD" Setting:

- Spring pre-load (3): From fully open, 8 turns clockwise
- MGCS mode: A2 - Comfort
- Stanchion protrusion (A) (\*\*\*) : 1 notch (4 mm - 0.16 in)

##### "TOURING" Setting:

- Spring pre-load (3): From fully open, 8 turns clockwise
- MGCS mode: A1 - Dynamic
- Stanchion protrusion (A) (\*\*\*) : 1 notch (4 mm - 0.16 in)

##### "RAIN" setting:

- Spring pre-load (3): From fully open, 8 turns clockwise
- MGCS mode: A2 - Comfort

- Stanchion protrusion (A) (\*\*\*) : 1 notch (4 mm - 0.16 in)

(\*\*\*) - this type of adjustment may only be made by an Authorised Moto Guzzi Dealer.

#### CAUTION



**ALL MODES CAN BE EDITED BY THE USER AND IT IS ALWAYS POSSIBLE TO RETURN EACH MODE TO THE FACTORY SETTINGS, AS EXPLAINED IN THE "ADVANCED FUNCTIONS" PARAGRAPH.**

**IF YOU WANT TO CHANGE THE FACTORY SETTINGS, TEST THE VEHICLE REPEATEDLY UNTIL THE OPTIMUM ADJUSTMENT IS OBTAINED.**

**IF NECESSARY, CONTACT AN Official Moto Guzzi Dealer.**

### Front brake lever adjustment

It is possible to adjust the distance between the end of the lever (1) and the grip (2), turning the adjuster (3).

- Push the control lever (1) forwards and turn the adjuster (3) until the lever (1) is at the desired distance.
- Turning the adjuster clockwise moves the lever (1) away from the handle (2).

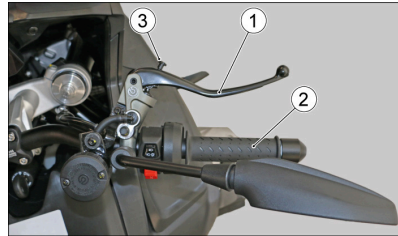

#### WARNING



**IF THE FRONT BRAKE LEVER MUST BE REMOVED, CHECKED AND CHANGED BY AN Official Moto Guzzi Dealership.**

### Adjusting the rear brake pedal

The control levers are positioned ergonomically when the vehicle is being assembled.

if necessary, it is possible to customise the position of the levers.

- Rest the vehicle on its stand.
- Partially undo the screw (1).
- Turn the cam (2) finding the best position for the pedal (3).
- Tighten the screw (1) and check the cam is stable in position.

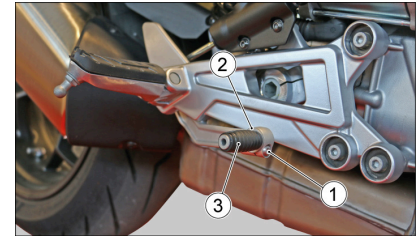

#### WARNING



**TO ADJUST THE BRAKE LEVER CLEARANCE, CONTACT AN Official Moto Guzzi Dealer.**

### Clutch lever adjustment

It is possible to adjust the distance between the end of the lever (1) and the grip (2), turning the adjuster (3).

- Push the control lever (1) forwards and turn the adjuster (3) until the lever (1) is at the desired distance.
- Turning the adjuster clockwise moves the lever (1) away from the handle (2).

#### WARNING



**CONTACT AN Official Moto Guzzi dealer TO REMOVE AND REPLACE THE CLUTCH LEVER.**

#### **WARNING**



**IN THE EVENT FAULTS AND/OR MALFUNCTIONS IN THE CLUTCH CONTROL, CONTACT AN Official Moto Guzzi dealer.**

## **Running-in**

Running in is essential to ensure the durability of the vehicle. During the first 1500 Km (932 mi), observe the following rules to ensure the reliability and performance of the vehicle throughout its lifetime:

- Avoid full throttle starts and hard acceleration;
- Avoid exceeding 4,500 rpm;
- Avoid hard or prolonged braking;
- Do not ride for prolonged periods at sustained high speed; preferably ride the motorcycle on varied routes with frequent, gentle acceleration and deceleration;
- Ride prudently to gradually gain familiarity with the motorcycle, testing progressively higher throttle apertures only as you gain confidence

**N.B.:**



**THE FULL PERFORMANCE OF THE VEHICLE IS ONLY AVAILABLE AFTER PERFORMING THE SERVICE AT THE END OF THE RUNNING IN PERIOD.**

#### **CAUTION**



**TO PREVENT THE RISK OF INJURY TO YOURSELF OR OTHERS AND/OR DAMAGE TO THE VEHICLE, TAKE THE YOUR MOTORCYCLE TO AN AUTHORISED Moto Guzzi DEALER AT THE SPECIFIED MILEAGE INTERVALS TO HAVE THE CHECKS LISTED IN THE "SCHEDULED MAINTENANCE TABLE" CARRIED OUT.**

## **Engine starter**

**This vehicle is extremely powerful and must be used carefully and driven with caution and respect for its power and potential.**

**Do not place objects inside the top fairing (between the handlebar and the instrument cluster), as this may impede the movements of the handlebar and obstruct visibility of the instruments.**

#### **CAUTION**



**EXHAUST FUMES CONTAIN CARBON MONOXIDE, AN EXTREMELY HARMFUL SUBSTANCE IF INHALED. NEVER START THE ENGINE IN A CLOSED OR INSUFFICIENTLY VENTILATED SPACE.**

#### **CAUTION**



**FAILURE TO OBSERVE THIS WARNING COULD LEAD TO UNCONSCIOUSNESS AND EVEN DEATH DUE TO SUFFOCATION.**

#### **CAUTION**



**WITH THE SIDE STAND LOWERED, THE ENGINE MAY ONLY BE STARTED WITH THE GEARBOX IN NEUTRAL. IF YOU ATTEMPT TO ENGAGE THE GEAR, THE ENGINE WILL STOP.**

**WITH THE SIDE STAND RETRACTED, THE ENGINE MAY BE STARTED WITH THE GEARBOX IN NEUTRAL OR**

### WITH THE GEAR ENGAGED AND THE CLUTCH LEVER OPERATED.

- Get on the motorcycle, assuming the correct driving posture.
- Make sure that the side stand has been fully retracted.
- Operate the front or rear brake (or both).
- Operate the clutch lever (1) and make sure that the transmission (2) is in neutral.

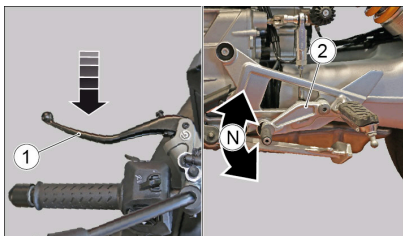

At this stage:

- Turn the ignition key (1) to "ON".
- The starting screen will be displayed on the digital display for about 2 seconds and then the screen with the standard parameters will appear.
- All the indicator lights on the dashboard will come on for about 2 seconds.
- Press the starter button (2) once only.
- With the engine operating normally, all instantaneous parameters will be visible in the digital display.



**N.B.:**



**IF THE LOW FUEL WARNING LIGHT ON THE DASHBOARD TURNS ON, REFUEL THE VEHICLE AT ONCE.**

**WARNING**



**INTENSE USE/ON THE TRACK IN RESERVE CAN DAMAGE THE ENGINE.**

**CAUTION**



**ON NEW VEHICLES, THE SHIFT LIGHT THRESHOLD IS SET TO 5200 RPM. RAISE THE THRESHOLD GRADUALLY UNTIL YOU HAVE BECOME FAMILIAR**

**WITH THE VEHICLE AND THE RUN-IN HAS BEEN COMPLETED.**

**N.B.:**



**AFTER A FEW SECONDS FROM THE ENGINE START-UP, THE START-UP BUTTON ASSUMES THE RIDING MODE CHANGE FUNCTION.**

**WARNING**



**IF THE GENERAL WARNING INDICATOR LIGHT ON THE DASHBOARD COMES ON, IT MEANS THAT THE CONTROL UNIT HAS ENCOUNTERED A FAULT, THEREFORE IT IS NECESSARY TO CONTACT AN Authorised Moto Guzzi Dealer.**



### WARNING



DO NOT SET OFF SUDDENLY WHEN THE ENGINE IS COLD. RIDE AT LOW SPEED FOR SEVERAL KILOMETRES. THIS WILL ALLOW THE ENGINE TO WARM UP AND REDUCE POLLUTING EMISSIONS AND FUEL CONSUMPTION.

### Setting off and riding

N.B.:



THE ECU INSTALLED ON THIS MOTORCYCLE COMPENSATES FOR INCREASED ELECTRIC POWER CONSUMPTION BY TEMPORARILY RAISING THE IDLE SPEED; VARIATIONS IN ENGINE SPEED

WITHIN THIS RANGE ARE THEREFORE NORMAL.

N.B.:



IF THE LOW FUEL WARNING LIGHT ON THE DASHBOARD TURNS ON, REFUEL THE VEHICLE AT ONCE.

N.B.:



IF THE MOTORCYCLE TURNS OFF ACCIDENTALLY THE ECU ALLOWS A RESTART WITHIN THE NEXT 5 SECONDS.

ONCE THIS PERIOD OF TIME HAS PASSED THE ECU WILL PREVENT STARTING FOR ANOTHER 3 SECONDS AND ONLY THEN WILL IT BE POSSIBLE TO START THE MOTORCYCLE.

CAUTION



PASSENGERS MUST BE SUITABLY INSTRUCTED ON HOW TO BEHAVE TO PREVENT DANGEROUS SITUATIONS WHEN RIDING.

BEFORE SETTING OFF, MAKE SURE THE STAND HAS BEEN COMPLETELY RETRACTED TO ITS POSITION.

To start:

- Turn on the engine.
- Adjust the inclination of the rear-view mirrors to ensure proper visibility.

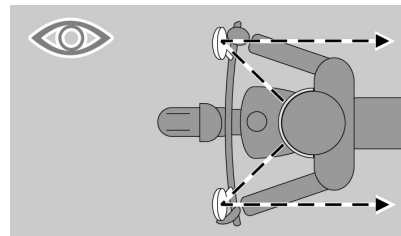

CAUTION



WITH THE VEHICLE AT STANDSTILL, PRACTICE USING THE REAR-VIEW MIRRORS. THE MIRRORS ARE CONVEX, SO OBJECTS MAY SEEM FARTHER AWAY THAN THEY REALLY ARE. THESE MIRRORS OFFER A WIDE-ANGLE VIEW AND ONLY

**EXPERIENCE HELPS YOU JUDGE THE DISTANCE SEPARATING YOU AND THE VEHICLE BEHIND.**

- With a closed throttle grip (Pos. A) and the engine idling, pull the clutch lever.
- Push the gear pedal (1) downward to insert the first gear.

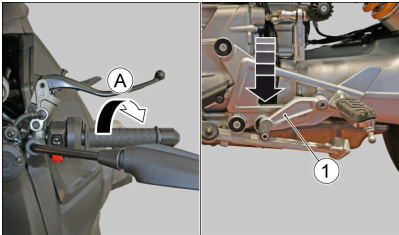

**WARNING**



**THIS VEHICLE IS EQUIPPED WITH AN ADVANCED TRANSMISSION THAT MAKES IT EASY TO ENGAGE NEUTRAL BETWEEN FIRST AND SECOND GEAR WHEN STATIONARY. DUE TO THE PECULIAR ARCHITECTURE OF THIS TRANSMISSION, IT IS NOT POSSIBLE, AT A STANDSTILL, TO SHIFT INTO ANOTHER GEAR BEYOND THE FIRST GEAR.**

**CAUTION**



**WHEN TURNING OFF THE VEHICLE, DO NOT RELEASE THE CLUTCH TOO QUICKLY OR SUDDENLY, AS THIS COULD CAUSE THE ENGINE TO STOP OR THE VEHICLE TO REAR UP ON THE BACK WHEEL. DO NOT ACCELERATE SUDDENLY WHEN RELEASING THE CLUTCH FOR THE SAME REASON.**

- Slowly release the clutch lever and accelerate by slightly turning the throttle grip at the same time (Pos. B).
- The vehicle starts moving forward.
- Ride at moderate speed for the first kilometres/miles to allow the engine to warm up.
- Speed up by gradually turning the throttle grip (Pos. B) without exceeding the recommended revs.
- To shift into second gear: Release the throttle grip, operate the clutch lever and lift the gearshift pedal (1), then release the clutch lever and accelerate.
- Repeat the last two steps whenever shifting into higher gears.

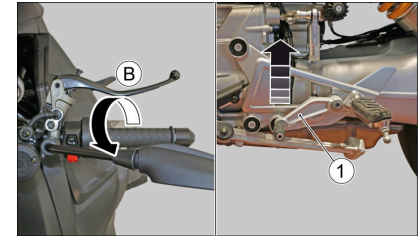

**CAUTION**



**RIDE IN THE CORRECT GEAR AND SPEED FOR THE CONDITIONS. DO NOT OPERATE THE THROTTLE GRIP ABRUPTLY.**

**N.B.:**



**IT IS RECOMMENDED YOU GO DOWN FROM A HIGHER GEAR TO A LOWER GEAR:**

- When riding downhill and under braking, using engine compression to increase braking power.
- When going uphill, when the engaged gear does not suit the speed (high gear,

moderate speed) and the number of engine revs falls.

#### CAUTION



**DOWN-SHIFT ONE GEAR AT A TIME; WHEN SHIFTING TO A LOWER GEAR, DOWN-SHIFTING MORE THAN ONE GEAR AT A TIME COULD OVER-REV THE ENGINE; THAT IS, THE MAXIMUM RPM VALUE PERMITTED FOR THE ENGINE COULD BE EXCEEDED.**

#### To slow down:

- Release the throttle grip (Pos. A).
- If necessary, pull the brake levers gently and reduce speed.
- Operate the clutch lever and lower the gearshift pedal (1) to engage a lower gear.
- Release the brake levers when it is operated.
- Release the clutch lever and accelerate moderately to get back into gear.

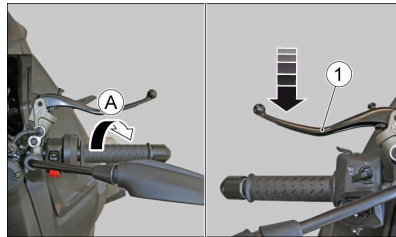

#### WARNING



**IN ORDER TO AVOID CLUTCH OVERHEATING, SHUT THE ENGINE OFF AS SOON AS POSSIBLE ONCE THE VEHICLE HAS STOPPED AND AT THE SAME TIME THE GEAR IS ENGAGED AND THE CLUTCH LEVER OPERATED.**

#### CAUTION



**STOP THE VEHICLE MAINLY USING THE FRONT BRAKE.**

**THE REAR BRAKE MUST ONLY BE USED TO BALANCE THE BRAKING EFFECT, AND ONLY TOGETHER WITH THE FRONT BRAKE.**

**WHEN STOPPING UPHILL, DECELERATE COMPLETELY AND ONLY USE THE BRAKES TO MAINTAIN THE VEHICLE IN THE STOPPED POSITION.**

**USING THE ENGINE TO KEEP THE MOTORCYCLE STOPPED COULD CAUSE THE CLUTCH TO OVERHEAT.**

**PROLONGED AND REPEATED USE OF THE BRAKES CAN CAUSE THEM TO OVERHEAT, RESULTING IN REDUCED BRAKING EFFECTIVENESS. ON LONG, STEEP DESCENTS, TO AVOID OVERHEATING THE BRAKE SYSTEM, REPEATED BUT NOT PROLONGED BRAKE APPLICATION IS RECOMMENDED TO REDUCE SPEED. IN THE EVENT OF OVERHEATING, THE VEHICLE MUST BE STOPPED AND THE BRAKE SYSTEM COOLED.**

**WHEN DRIVING DOWNHILL, NEVER RIDE WITH THE ENGINE TURNED OFF. WHEN RIDING ON WET SURFACES OR SURFACES WITH POOR GRIP (SNOW, ICE, MUD, ETC.) USE MODERATE SPEED, AVOID SUDDEN BRAKING OR MANOEUVRES THAT MAY CAUSE TO A LOSS OF TRACTION AND POSSIBLY TO A FALL OR CRASH.**

#### Engine stop

- Release the throttle grip (Pos. A), brake gradually and simultaneously downshift to slow down.

Once the speed is reduced, before stopping the vehicle:

- Pull the clutch lever (1) to prevent the engine from stalling

When the vehicle is at standstill:

- Set the gearshift lever in neutral (symbol "N" visible on the digital display and green "N" indicator light lit).
- Release the clutch lever (1).
- While at a temporary halt, keep at least one of the vehicle brakes held.

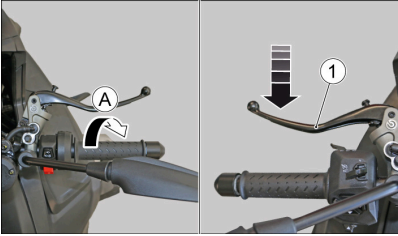

**CAUTION**



**WHENEVER POSSIBLE, AVOID ROUGH BRAKING, SUDDEN DECELERATION AND BRAKING IN EXCESS.**

### It is easy to park anywhere on the road

It is very important to select an adequate parking spot, in compliance with road signals and the guidelines described below.

**CAUTION**



**PARK ON SAFE AND LEVEL GROUND TO PREVENT THE VEHICLE FROM FALLING.**

**DO NOT LEAN THE VEHICLE AGAINST A WALL OR LAY IT ON THE GROUND.**

**ENSURE THAT THE VEHICLE AND, IN PARTICULAR, PARTS OF THE VEHICLE WHICH MAY BECOME HOT (ENGINE, OIL RADIATOR AND LINES, EXHAUST SYSTEM, BRAKE DISCS) ARE NOT A HAZARD TO PERSONS OR CHILDREN. DO NOT LEAVE YOUR VEHICLE UNATTENDED WITH THE ENGINE ON OR THE KEY IN THE IGNITION SWITCH.**

**WARNING**



**IF THE VEHICLE FALLS OR IS ON A STEEP INCLINE FUEL CAN LEAK.**

**CAUTION**



**FUEL USED TO DRIVE EXPLOSION ENGINES IS HIGHLY INFLAMMABLE AND CAN BECOME EXPLOSIVE UNDER SPECIFIC CONDITIONS. IT IS THEREFORE RECOMMENDED TO CARRY OUT REFUELLING AND MAINTENANCE PROCEDURES IN A VENTILATED AREA WITH THE ENGINE SWITCHED OFF. DO NOT SMOKE DURING REFUELLING AND NEAR FUEL VAPOURS, AVOIDING ANY CONTACT WITH NAKED FLAMES, SPARKS OR OTHER SOURCES WHICH MAY CAUSE THEM TO IGNITE OR EXPLODE.**

**DO NOT DISPERSE FUEL IN THE ENVIRONMENT. ALWAYS USE APPROPRIATE DISPOSAL METHODS.**

**KEEP OUT OF THE REACH OF CHILDREN .**

**CAUTION**



**DO NOT REST THE RIDER OR PASSENGER WEIGHT ON THE SIDE STAND.**

## Catalytic converter

The vehicle is equipped with a silencer with a "platinum - palladium - rhodium three-way" metal catalytic converter.

This device oxidises the CO (carbon monoxide) producing carbon dioxide, and the HC (unburned hydrocarbons) producing water vapour and CO<sub>2</sub> and reduces NO<sub>x</sub> (nitrogen oxide) producing oxygen and nitrogen present in the exhaust fumes.

### CAUTION



**AVOID PARKING THE VEHICLE NEAR DRY BRUSHWOOD OR IN PLACES ACCESSIBLE TO CHILDREN, AS THE CATALYTIC CONVERTER IS VERY HOT WHEN IN USE; THEREFORE, PAY THE UTMOST ATTENTION AND DO NOT TOUCH IT UNTIL IT HAS COMPLETELY COOLED DOWN.**

### WARNING



**DO NOT USE LEADED PETROL AS IT WILL DAMAGE THE CATALYTIC CONVERTER.**

Vehicle owners are warned that the law may prohibit the following:

- the removal of any device or element belonging to a new vehicle or any other action by anyone leading to render it non-operating, if not for maintenance, repair or replacement reasons, in order to control noise emission before the sale or delivery of the vehicle to the ultimate buyer or while it is used;
- using the vehicle after that device or element has been removed or rendered non-operating.

Check the exhaust silencer and the silencer pipes, ensuring there are no signs of penetrative corrosion and that the exhaust system works properly.

If the noise produced by the exhaust system increases, get immediately in touch with the Dealer or with a Moto Guzzi authorised repair shop.

### WARNING



**DO NOT TAMPER WITH THE EXHAUST SYSTEM.**

## Stand

### SIDE STAND

If the stand has been folded up for any manoeuvre (for example, when the vehicle

is in motion), place the vehicle on the stand again as follows:

- Grasp the left grip and put the right hand on the upper rear part of the vehicle.
- Push the side stand with your right foot to fully extend the stand.
- Lean the vehicle until the stand touches the ground.
- Turn the handlebar fully leftwards.



### CAUTION



**CHECK THE STABILITY OF THE VEHICLE.**

A safety switch (2) is installed on the side stand (1) to inhibit ignition or to stop the engine when a gear is engaged and the side stand (1) is lowered.

**CHECK THAT THERE IS NO DIRT IN THE SWITCH AREA. IF POSSIBLE, CLEAN THE AREA AND CHECK THE LIGHT ON**

**THE DASHBOARD WITH THE STAND DOWN.**

**IF WITH THE STAND OPEN, THE SIDE STAND WARNING LIGHT REMAINS OFF DESPITE CLEANING, PLEASE CONTACT an Authorised Moto Guzzi Dealer.**

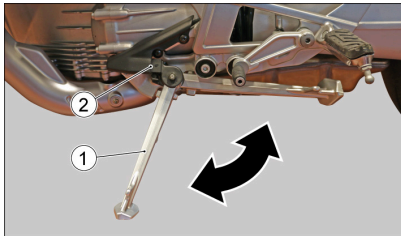

**theft prevention tips**

**CAUTION**

**WHEN USING A DISC LOCKING DEVICE, PAY UTMOST ATTENTION TO REMOVE IT BEFORE RIDING. FAILURE TO OBSERVE THIS WARNING MAY CAUSE SERIOUS DAMAGE TO THE BRAKING SYSTEM AND ACCIDENTS WITH CONSEQUENT PHYSICAL INJURIES OR EVEN DEATH.**

**NEVER** leave the ignition key in the lock and always use the steering lock. Park the vehicle in a safe place such as a garage

or a place with guards. Whenever possible, use an additional anti-theft device. Make sure all vehicle documents are in order and the road tax paid. Write down your personal details and telephone number on this page to help identifying the owner in case of vehicle retrieval after a theft.

SURNAME: .....

FIRST NAME: .....

ADDRESS: .....

TELEPHONE NO.: .....

**N.B.:**

**IN MANY CASES, STOLEN VEHICLES CAN BE IDENTIFIED BY DATA IN THE USE / MAINTENANCE BOOKLET.**

**Safe riding**

**MAIN SAFETY RULES**

The following instructions refer to the normal use of your vehicle and must be carefully observed. Observing these rules will allow you to increase your safety and that of the persons around you as well as maximise the life and usefulness of your vehicle. Two-wheeled vehicles obviously do not offer some of the protections normally provided on cars, so it is essential to wear suitable protective clothing. In particular, when riding

the vehicle, always wear a helmet, gloves, protective goggles and a heavy jacket, sturdy footwear and durable long trousers. However, it must always be kept in mind that even the best clothing and helmet cannot protect you in the event of a fall or collision with another vehicle. These features protect you best from scratches and abrasions, but their protective function is minimal in the event of an impact.

Make sure you meet all the requirements of the local law, including driver's license, minimum age, adequate preparation, insurance, taxes, vehicle registration, license plate, etc.



As soon as you receive the vehicle, familiarise yourself by practising in areas with low traffic intensity. Avoid driving the vehicle in heavy traffic areas until you have gained a good experience and total safety in riding.

Although this vehicle is approved for use on motorways and ring roads, it is recommended that you do not travel on these roads at high speed until you have

become very familiar with the vehicle and have achieved a high degree of skill in use.

A new vehicle must undergo an accurate break-in. Before starting the engine, make sure the brake, clutch, drive and throttle controls are working properly and check that the oil and fuel level is adequate. The exhaust system, brakes and some vehicle components can get very hot while riding. Do not touch these components.

Consumption of certain drugs and medicines, illegal or prescribed, as well as alcohol greatly increases the risk of accidents.

Do not drive while under the influence of alcohol or drugs, whether they are illegal or licensed by a doctor. Make sure that you are in good physical condition before driving your vehicle.

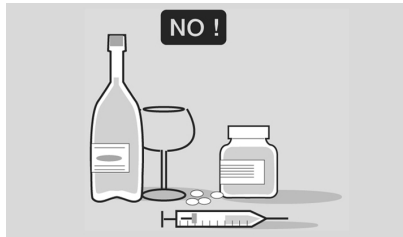

Do not drive in conditions of particular fatigue or tiredness. Alcohol, drugs and fatigue are the main cause of accidents. Many accidents are due to the driver's inexperience.

Do not ride your vehicle until you have received training from a recognized organization such as the Motorcycle Safety Foundation.

Always keep in mind that driving a two-wheeled vehicle, while easy and fun, is very different from driving a car. Not necessarily an experienced car driver is able to safely drive a two-wheeled vehicle.

**NEVER** lend the vehicle to other people if you are not sure that they are experts and in possession of a driving license. Respect all the rules of the road traffic code. In particular, pay attention to all warning, traffic regulation and information signs.

Avoid showing off with dangerous manoeuvres (e.g. rear up). In particular, respect the speed limits and remember that the conditions of the road surface vary according to the weather conditions; wet and icy roads are dangerous especially at high speed.



Car drivers often find it difficult to see two-wheeled vehicles, so always give priority to

cars even in cases where according to the road traffic code you would have priority.

Before changing lanes, always check that the road is clear behind you. Do not rely solely on the rear view mirror as it could underestimate the distance and speed of a vehicle or even not see it at all.

Avoid obstacles that could damage the vehicle or lead to loss of control of the vehicle.

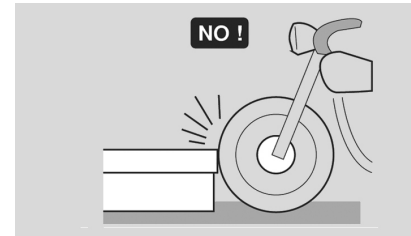

Do not drive close to vehicles like trucks or cars, in front of you and do not remain in their lane to increase speed. In the event of an accident, motorcycles, scooters and mopeds do not offer the same level of protection as cars.

Especially the legs are exposed to the risk of injury. The additional installation of leg pads can concretely increase the risk of injury and the severity in the event of an accident.

Do not install leg pads available on the spare parts and accessories market. Failure to follow these instructions can result in serious injury or even death.

Always ride with both hands on the handlebars and feet on the foot pegs.



Never change gear without using the clutch if your vehicle is equipped with one. Do not operate the shift lever or other controls abruptly and suddenly.

Misuse of this type could damage the internal components of the vehicle resulting in seizure, loss of control, accidents and serious or even fatal injuries.

Remain seated while driving. Do not stand up or try to stretch yourself while riding the vehicle. If you need to rest, pull over at a safe point on the road.

It is very important for your safety to always drive with the utmost attention. Pay attention to your actions, do not be distracted by other vehicles, persons and or things near the road, etc.

Do not smoke, eat, drink, read, etc. while driving the vehicle. If you need to consult a road map, pull over and carry out the operation in complete safety.

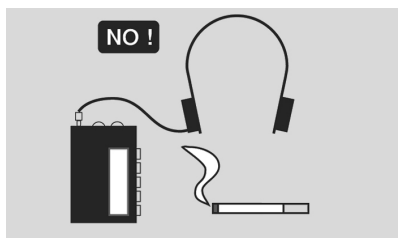

Use only the fuels and lubricants specified for the vehicle listed in the RECOMMENDED PRODUCTS TABLE; regularly check the coolant, fuel and oil levels.

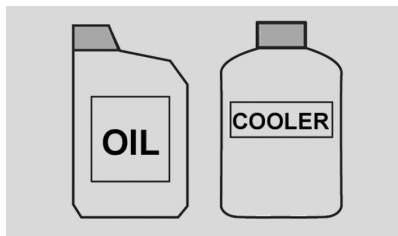

If the throttle remains locked, it could result in a collision with another vehicle or a fall. If the throttle remains locked, stop the engine with the engine stop switch located on the right handlebar.

Do not try to restart the engine until the throttle has been repaired and is fully functional. Failure to observe this warning can result in loss of control resulting in serious injury or even death.

### CAUTION



**IN THE EVENT OF AN EMERGENCY CAUSING THE THROTTLE TO LOCK, ALWAYS STOP THE ENGINE USING THE ENGINE STOP SWITCH LOCATED NEAR THE THROTTLE GRIP.**

**DO NOT OPERATE THE VEHICLE IF THE THROTTLE DOES NOT AUTOMATICALLY RETURN COMPLETELY TO IDLE ONCE THE THROTTLE GRIP IS RELEASED.**

**FOR REPAIRS, PLEASE CONTACT YOUR LOCAL Moto Guzzi Dealer. FAILURE TO OBSERVE THIS WARNING COULD LEAD TO SERIOUS ACCIDENT WITH CONSEQUENT INJURY OR EVEN DEATH.**

If you have been involved in an accident with your vehicle, make sure that the control levers, pipes, cables, brake system or other vital components have not been damaged. If your vehicle has been involved in an accident, immediately contact your local **Moto Guzzi** dealer who has the necessary equipment and knowledge to check for any damage that could compromise your safety.

Your **Moto Guzzi** dealer can help you to solve all safety problems under the condition that all mechanical malfunctions are reported to him.

Do not use the damaged vehicle. A damaged vehicle could lose stability or have other problems that could increase the risk of an accident resulting in serious injury or even death.

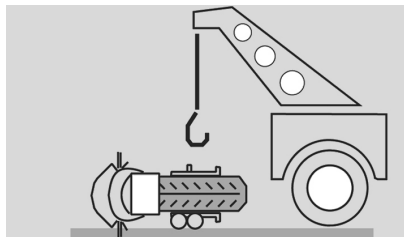

Do not try to change the position, angle or colour of your license plate. The license plate shall not be covered in any way, not even with transparent plastic. Do not modify the safety features of your vehicle, especially components such as turn indicators, rear view mirrors, lights or horns.

Any modification to the vehicle will result in the cancellation of the warranty. Do not modify the engine in order to increase its power. This could cause irreparable damage to the engine as well as compromise its performance and vehicle handling resulting in a fall and serious or even fatal injuries.

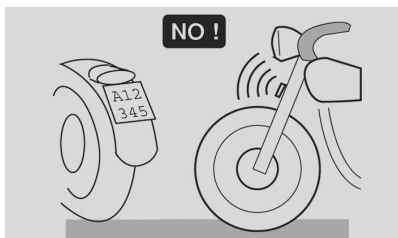

To repair your vehicle, use only original **Moto Guzzi** accessories or **Moto Guzzi** approved accessories. The use of aftermarket accessories and parts can seriously affect the safety of your vehicle as well as its performance and use. Any changes that affect performance or safety void the entire warranty.

Tampering with the emission and noise control system is prohibited by law and can be severely punished.

For some jurisdictions, vehicle confiscation is also provided.



This vehicle is not intended to be equipped with a sidecar or to be used to tow trailers or other vehicles.

**Moto Guzzi** does not produce sidecars or trailers and can therefore not predict the consequences that these accessories may have on the handling and stability of the vehicle: however, it is warned that these effects could be negative and the guarantee is not recognised for any damage to components of the vehicle due to the use of accessories of this type.



Never use your vehicle to compete with other vehicles.

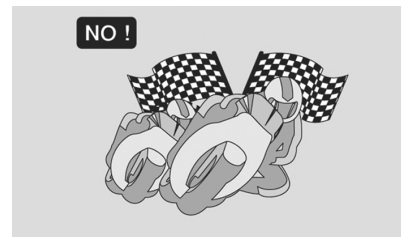

Brake using both the front and rear brakes. Using only one brake in the event of hard braking could cause the vehicle to skid or cause the driver to lose control of the vehicle.

When driving downhill, take advantage of the engine's braking action by selecting the same gear or a lower gear than those normally used uphill. Use the front and rear brake with moderation.

Always travel at an adequate speed and avoid unnecessary sudden acceleration not only for greater safety, but also to reduce fuel consumption and increase the life of the vehicle.

When using the vehicle on wet or slippery surfaces, always bear in mind that grip decreases significantly. In these conditions, always manoeuvre the vehicle slowly and with the utmost caution.

Accelerating, braking, or sudden turns can cause you to lose control of the vehicle. When grip is reduced, accelerate and slow down using the engine braking force as much as possible. Avoid braking hard and too fast.

Slowly open and close the throttle to avoid spinning or skidding the rear wheel.

Slow down and drive carefully on uneven road surfaces.



Avoid accelerating by turning the throttle completely except in cases of absolute necessity such as overtaking.

Do not let the engine work "under stress", that means too low a number of revolutions. Downshift to a lower gear. Do not run the engine excessively. Observe the red line on the speedometer.

Remember that excessively aggressive cornering can cause the tyre to lose grip on the tyre sidewall resulting in a fall and serious injury or even death.

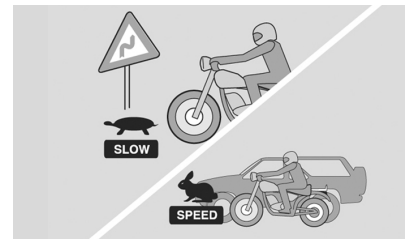

Always respect the speed limits imposed by law taking into consideration that it is not always possible to drive up to the indicated speed limit in all road conditions. Slowing down slightly increases your safety considerably in all road conditions.

Do not ride the vehicle off-road.

Do not tamper with the exhaust or emissions control system of your vehicle as this is not only a form of environmental protection, but could incur criminal penalties.



**CLOTHING**

Before riding the vehicle, make sure your clothing is in suitable condition. Wear the helmet correctly making sure that the visor or goggles are clean.

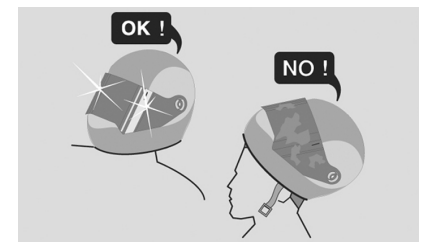

Research and experience have shown that drivers of other vehicles often do not see the vehicles or motorcyclists. To make yourself more visible to other drivers, wear reflective clothing such as light-refracting vests or other types of clothing with reflective areas sewn onto the jacket, pants and gloves. Be especially careful of trucks and cars arriving from the oncoming lane as they may turn left right in front of you. Many traffic accidents are caused by a driver on the opposite side

turning left without considering the vehicle in front.

Inevitably, the driver in front of you will swear only having seen you when, after turning, being in your lane. Drive carefully!

Wear appropriate protective clothes, preferably light-coloured and/or in reflective material. This way you are more visible to other drivers, considerably reducing the risk of being hit and enjoying greater protection in the event of an accident.

Always wear helmet.

Clothing should be particularly tight and closed at the wrists and ankles. Cords, belts and ties shall not hang out; prevent these and other objects from interfering with driving as they can get entangled with moving parts or driving mechanisms.

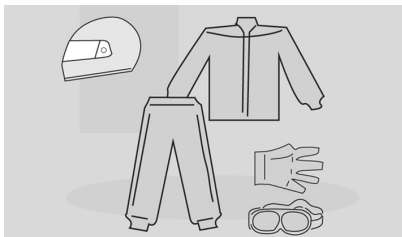

Do not keep sharp objects in your pocket which could be dangerous in case of a fall, e.g. keys, lead pencil, etc. Make sure that all other passenger also follow these recommendations.

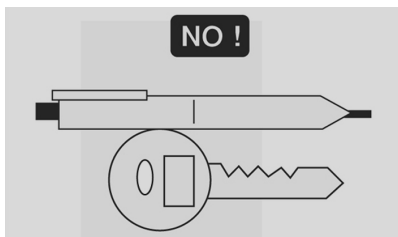

### ACCESSORIES

The vehicle owner is responsible for the selection, installation and use of all accessories.

Installing inappropriate accessories or overloading the vehicle could make the vehicle unstable and lead to accidents resulting in serious injury or even death. Windscreens are particularly dangerous in the event of an accident as if they break they could injure or cut the rider. In case of doubt about any accessory to be installed or any load to be transported, we recommend you to consult your local **Moto Guzzi** dealer in advance.

Do not install accessories which cover or limit the operation of the horns or lights, which limit the suspension travel and the steering angle, which hinder the operation of the controls and reduce the ground clearance and lean angle when cornering .

Do not use accessories that hinder access to the controls as they may increase the reaction time in case of an emergency.

The fairings and windscreens mounted on the vehicle can give rise to aerodynamic forces such as to compromise the stability of the vehicle while riding, particularly at high speeds.

Make sure that everything that is mounted on the vehicle is securely fixed, cannot come off and lock wheels, forks, etc. Do not install electrical accessories and do not modify the vehicle electrical system. Any component that could cause an overload or electrical fault could result in the vehicle being stopped immediately, the lights or beeps turned off or dimmed, or malfunction of other safety accessories. Use only original **Moto Guzzi** accessories.

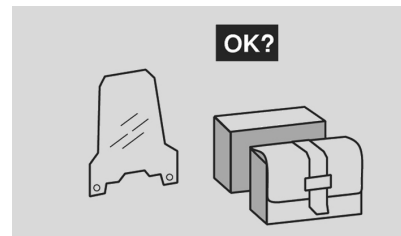

### LOADING

Do not overload the vehicle.

Secure bags or luggage as close to the vehicle's centre of gravity as possible and distribute the load as evenly as possible between the two sides to minimise imbalance. Always remember that loads tend to loosen during travel and therefore often check the safety of your load.

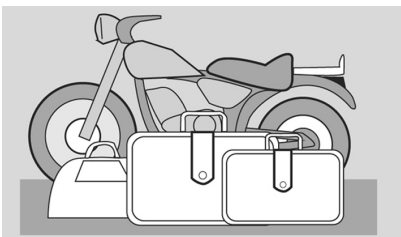

Do not let objects hang from the vehicle's semi-handlebars, mudguards or forks as they may impair the handling of the vehicle and prevent you from avoiding an accident. Failure to observe this warning can lead to a fall resulting in serious injury or even death.

Do not ride with the helmet hanging from the strap as it could easily get caught on the wheels, mudguard or forks causing a fall and result in serious injury or even death.



Only carry a passenger if the vehicle is equipped with passenger footrests, passenger grips and saddle.

When carrying a passenger, always remember that the vehicle has reduced handling, that the brakes are less effective

and that the centre of gravity is higher and further back.

This favours the detachment of the front wheel from the ground especially during acceleration. Therefore, avoid abrupt acceleration and braking. Many accidents are caused by inexperienced riders carrying a passenger. Remember to carry out the riding manoeuvres with greater tolerance in case of excessive passenger weight.

Avoid sudden and excessive acceleration. Always slowdown in advance and calculate longer braking and manoeuvring distances. Failure to observe these instructions could result in the vehicle overturning or other accidents resulting in serious injury or even death.

Never transport items that are not anchored and make sure that everything transported on the vehicle is carefully secured.

Do not carry luggage that protrudes from the luggage rack or that covers the lights, horn and headlamps.

Do not carry animals or children on the glove box or luggage rack.

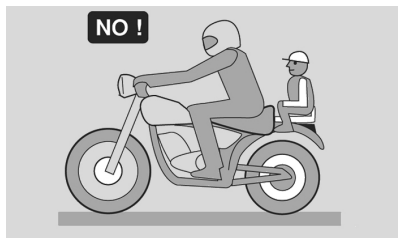

Never exceed the maximum load indicated for each bag.

Overloading your vehicle can seriously reduce its stability and handling leading to a fall resulting in serious injury or even death.

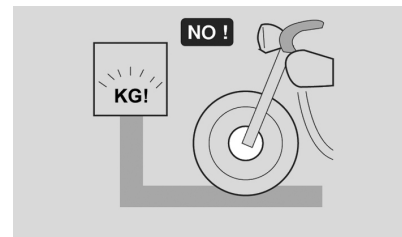

## Basic safety rules

The following recommendations should receive your maximum attention, because they are provided to increase your safety, and decrease damage to people, things and vehicles, in the case of a fall of the rider or passenger from the vehicle and/or from the fall or overturning of the vehicle.

Mounting and dismounting the vehicle should always be performed with total freedom of movement and with the hands free of all objects. (i.e.- objects, helmet, gloves, or glasses).

Mount and dismount only on the left side of the vehicle, and only with the side stand lowered.

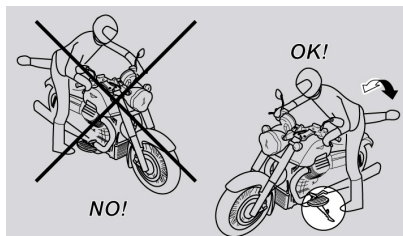

The stand is designed to support the weight of the vehicle and a small additional weight, which does not include the rider and passenger.

Mounting into driving position, with the side stand in place, is permitted only to prevent the possibility of the vehicle falling or overturn, and does not indicate the possibility for the rider and passenger's weight to be placed on the side stand.

During mounting and dismounting the vehicle's weight can cause a loss of balance, with consequent loss of equilibrium and the possibility of falling or overturning.

#### CAUTION



**THE RIDER SHOULD ALWAYS BE THE FIRST TO GET ON AND THE LAST TO GET OFF THE VEHICLE AND SHOULD CONTROL THE STABILITY AND BALANCE OF THE VEHICLE**

#### WHEN THE PASSENGER GETS ON AND OFF.

In any case, the passenger should mount and dismount the vehicle using caution to avoid causing the vehicle or the rider to lose balance.

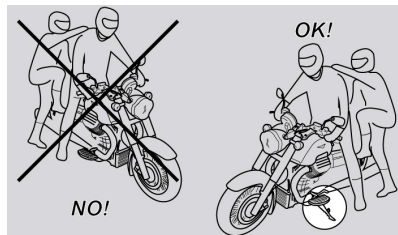

#### CAUTION



**THE RIDER MUST INSTRUCT THE PASSENGER HOW TO GET ON AND OFF THE VEHICLE.**

**THE VEHICLE INCLUDES PASSENGER FOOTRESTS WHICH SHOULD BE USED DURING MOUNTING AND DISMOUNTING. THE PASSENGER SHOULD ALWAYS USE THE LEFT FOOTREST FOR MOUNTING AND DISMOUNTING FROM THE VEHICLE.**

**DO NOT DISMOUNT OR EVEN ATTEMPT TO DISMOUNT BY JUMPING OR STRETCHING OUT YOUR LEG IN**

**ORDER TO TOUCH THE GROUND. IN BOTH CASES THE STABILITY AND EQUILIBRIUM OF THE VEHICLE COULD BE COMPROMISED.**

#### CAUTION



**BAGGAGE OR OBJECTS ATTACHED TO THE REAR PART OF THE VEHICLE CAN CREATE AN OBSTACLE DURING MOUNTING AND DISMOUNTING FROM THE VEHICLE.**

**IN ALL CASES, THINK AHEAD AND MOVE YOUR RIGHT LEG CAREFULLY, AS IT WILL HAVE TO AVOID AND CLEAR THE REAR PART OF THE VEHICLE (INCLUDING BAGGAGE AND THE TAIL FAIRING) WITHOUT CAUSING LOSS OF BALANCE.**

(if applicable)

#### CAUTION



**BEFORE DEPARTURE, MAKE SURE THAT THE CASES ARE CLOSED AND CORRECTLY FASTENED TO THE VEHICLE.**

**THE CASES MUST NOT BE USED AS SUPPORT AND THE HANDLES MUST NOT BE USED AS ANCHOR POINTS FOR THE PASSENGER.**

**MOUNTING**

- Grip the handlebar properly and mount the vehicle without placing your weight upon the side stand.

**CAUTION**



**IN THE CASE THAT YOU ARE NOT ABLE TO REST BOTH FEET ON THE GROUND, PUT THE RIGHT FOOT ON THE GROUND, (IN THE CASE OF A LOSS OF BALANCE THE LEFT SIDE IS "PROTECTED" BY THE SIDE STAND) AND KEEP YOUR LEFT FOOT READY TO BE POSITIONED.**

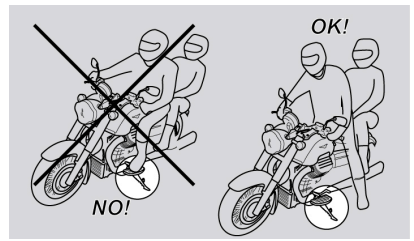

- Place both feet on the ground and straighten the vehicle into the

driving position, always maintaining its equilibrium.

**CAUTION**



**THE RIDER SHOULD NOT OPEN OR TRY TO OPEN THE PASSENGER FOOTRESTS FROM THE RIDER'S SEAT, AS IT COULD COMPROMISE THE STABILITY AND BALANCE OF THE VEHICLE.**

- Have the passenger open the two passenger foot pegs.
- Show the passenger how to mount the vehicle.
- Use your left foot to push on the side stand and make it fully return to its position.

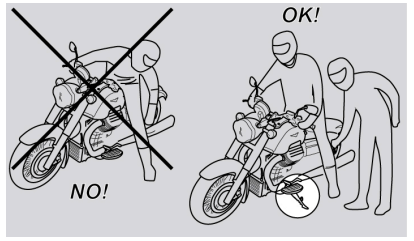

**DISMOUNTING**

- Select an appropriate parking spot.
- Stop the vehicle.

**CAUTION**



**MAKE SURE THAT THE GROUND ON WHICH THE MOTORCYCLE IS PARKED IS FIRM, EVEN AND FREE OF OBSTACLES.**

- Use the heel of your left foot to completely open the side stand.

**CAUTION**



**IN THE CASE THAT YOU ARE NOT ABLE TO REST BOTH FEET ON THE GROUND, PUT THE RIGHT FOOT ON THE GROUND, (IN THE CASE OF A LOSS OF BALANCE THE LEFT SIDE IS "PROTECTED" BY THE SIDE STAND) AND KEEP YOUR LEFT FOOT READY TO BE POSITIONED.**

- Place both feet on the ground and keep the vehicle balanced in the driving position.
- Show the passenger how to dismount from the vehicle.

**CAUTION**



**RISK OF FALLING OR OVERTURNING.**

**MAKE SURE THE PASSENGER HAS COME DOWN FROM THE VEHICLE.**

**DO NOT PLACE YOUR WEIGHT UPON THE SIDE STAND.**

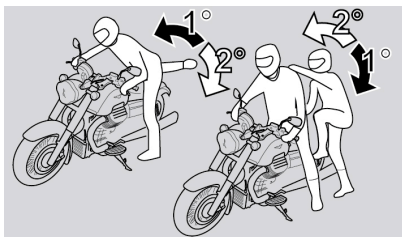

- Lean the motorcycle until the stand touches the ground.
- Correctly grip the handlebar, and dismount from the vehicle.
- Turn the handlebar completely to the left.
- Place the passenger footrest in its place.

**CAUTION**



**CHECK THE STABILITY OF THE VEHICLE.**

# V100 Mandello - V100 Mandello S



## CHAPTER 04 Maintenance

## Foreword

In general terms, scheduled maintenance can be carried out by the owner; however, some operations may require specific tools and technical training. For periodic maintenance, servicing or technical advice, contact an **Official Moto Guzzi Dealer** for prompt and accurate service.

**N.B.:**



THE ELECTRONIC CONTROL SYSTEM OF THIS VEHICLE IDENTIFIES FAULTS IN REAL TIME AND STORES THEM IN ITS MEMORY FOR SUBSEQUENT READING WITH THE DIAGNOSTIC SYSTEM USED BY Authorised Moto Guzzi Dealers.

ANY TIME THE IGNITION SWITCH IS SET TO "ON", THE "GENERAL ALARM" WARNING LIGHT ON THE INSTRUMENT PANEL TURNS ON FOR THREE SECONDS. IF THE WARNING LIGHT TURNS OFF, IT MEANS THAT THERE ARE NO MALFUNCTIONS.

**N.B.:**



**CARRY OUT MAINTENANCE OPERATIONS AT HALF THE INTERVALS SPECIFIED IF THE VEHICLE IS USED IN PARTICULAR RAINY OR DUSTY CONDITIONS, OFF ROAD OR FOR TRACK USE.**

## Engine oil level

**CAUTION**



CORRECT VEHICLE LUBRICATION IS A VERY DELICATE OPERATION FOR THE SAFETY. PAY ATTENTION TO KEEP THE LUBRICANT AT THE RIGHT LEVEL AND TO USE A GOOD QUALITY OIL OF THE CORRECT TYPE FOR YOUR VEHICLE OTHERWISE, THERE COULD BE ENGINE GRIPPING WHICH CAN CAUSE SERIOUS ACCIDENT OR EVEN DEATH.

**CAUTION**



USE LATEX GLOVES FOR MAINTENANCE OPERATIONS THAT REQUIRE CONTACT WITH THE USED OIL. THE USE OF ENGINE OIL CAN CAUSE SKIN TUMOURS IF HANDLED FOR A LONG TIME AND DAILY.

**CAREFULLY WASH YOUR HANDS WITH WATER AND SOAP AFTER USING USED ENGINE OIL.**

**KEEP OUT OF THE REACH OF CHILDREN.**

**DISPOSE OF OIL CORRECTLY.**

**WARNING**



**PAY UTMOST ATTENTION WHEN PUTTING OIL IN YOUR VEHICLE NOT TO SPILL IT OUT.**

**IMMEDIATELY CLEAN ANY DROP OF SPILLED OIL AS THE OIL CAN COMPROMISE THE FINISHING OF YOUR VEHICLE. FURTHER, OIL MAKES TYRES EXTREMELY SLIPPERY AND THUS INCREASES THE RISK OF DANGEROUS ACCIDENTS AND SITUATIONS.**

**IN CASE OF OIL LOSS, DO NOT DRIVE YOUR VEHICLE. BEFORE USING THE VEHICLE, HAVE IT REPAIRED BY AN Official Moto Guzzi Dealer.**

**CAUTION**



IF A POP-UP APPEARS ON THE DISPLAY WITH THE MESSAGE "ALARM OIL PRESSURE" OR "ALARM OIL SENSOR" AND AT THE SAME TIME THE GENERAL WARNING ICON LIGHTS UP AFTER THE ENGINE HAS BEEN STARTED OR WHILE RIDING, THIS MEANS THAT THE OIL IS NOT BUILDING ENOUGH PRESSURE OR AN OIL PRESSURE SENSOR ANOMALY HAS BEEN DETECTED. IN BOTH CASES, STOP THE ENGINE IMMEDIATELY AND CONTACT AN Official Moto Guzzi Dealer. FAILURE TO FOLLOW THIS WARNING CAN LEAD TO ENGINE SEIZURE, WHICH CAN CAUSE SERIOUS ACCIDENTS, EVEN DEATH.



### Checking the engine oil level

Check the engine oil level frequently.

**N.B.:**



THE MAINTENANCE INTERVALS PRESCRIBED BY THE SCHEDULED MAINTENANCE TABLE MUST BE CONSIDERED AS A GENERAL GUIDE FOR USING THE VEHICLE IN NORMAL RUNNING CONDITIONS.

IT MAY BE NECESSARY TO REDUCE THE MAINTENANCE INTERVALS UNDER SOME PARTICULAR CONDITIONS. ESPECIALLY WHEN USED IN GEOGRAPHICAL LOCATIONS WITH ADVERSE CLIMATIC CONDITIONS, USE ON UNEVEN GROUND OR SEVERE INDIVIDUAL USE.

#### WARNING



THE OIL LEVEL MUST BE CHECKED WHEN THE ENGINE IS WARM.

#### WARNING



DO NOT LET THE ENGINE IDLE WITH THE VEHICLE AT A STANDSTILL TO

WARM UP THE ENGINE AND OBTAIN THE OPERATING TEMPERATURE OF ENGINE OIL.

PREFERABLY CHECK THE OIL AFTER A JOURNEY OF AFTER TRAVELLING APPROXIMATELY 15 Km (10 miles) IN EXTRA-URBAN CONDITIONS (ENOUGH TO WARM UP THE ENGINE OIL TO OPERATING TEMPERATURE).

- Shut off the engine and wait a few seconds;
- Keep the vehicle upright with both wheels on the ground;
- Make sure that the vehicle is on a level surface;
- Unscrew the oil filler cap with dipstick and remove it from the crankcase;

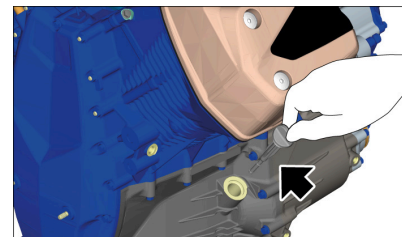

- Wipe the dipstick clean and put the dipstick and filler cap back into place **without tightening**;
- Remove the cap and dipstick again and check the engine oil level;

- The oil level is correct when it close to the "MAX" mark. Otherwise top off the engine oil.

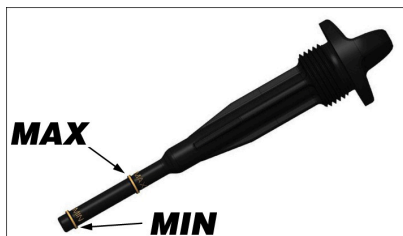
**WARNING**

THE OIL LEVEL MUST NEVER DROP BELOW THE MINIMUM MARKING OR EXCEED THE MAXIMUM MARKING; AN OIL LEVEL NOT WITHIN THE MINIMUM AND MAXIMUM MARKINGS MAY CAUSE SEVERE ENGINE DAMAGE.

**Engine oil top-up****WARNING**

**IF IT IS NECESSARY TO TOP UP THE ENGINE OIL LEVEL, CONTACT AN official Moto Guzzi dealer.**

**Engine oil change****WARNING**

THE ENGINE OIL MUST BE CHECKED AND CHANGED BY AN Official Moto Guzzi Dealership.

**Engine oil filter replacement****WARNING**

THE ENGINE OIL FILTER MUST BE CHECKED AND CHANGED BY AN Official Moto Guzzi Dealership.

**Bevel gear oil level****WARNING**

TO TOP-UP OR CHANGE THE OIL IN THE CARDAN SHAFT TRANSMISSION

**UNIT, CONTACT AN Official Moto Guzzi Dealer.**

**Tyres**

This vehicle is fitted with tubeless tyres (without inner tubes).

**CAUTION**

CHECK TYRE INFLATION PRESSURE REGULARLY AT AMBIENT TEMPERATURE. MEASUREMENTS MAY BE INCORRECT IF TYRES ARE WARM. CHECK PRESSURE MAINLY BEFORE AND AFTER LONG TRIPS. AN OVER-INFLATED TYRE WILL PROVIDE A HARSH RIDE AS SURFACE UNEVENNESS IS NOT CUSHIONED AND IS SENT TO THE HANDLEBAR, THUS REDUCING GRIP AND ROAD HOLDING SPECIALLY WHEN CORNERING.

ON THE OTHER HAND, AN UNDER-INFLATED TYRE CAUSES THE CONTACT PATCH TO INCLUDE A LARGER PORTION OF THE TYRE SIDE WALLS. IF SO, THE TYRE MIGHT SLIP ON OR GET DETACHED FROM THE WHEEL RIM, RESULTING IN LOSS OF CONTROL OVER THE VEHICLE.

EVENTUALLY THE VEHICLE MIGHT SKID IN A BEND.

**CHECK THE SURFACE CONDITION AND WEAR BECAUSE POOR TYRE CONDITION COULD COMPROMISE GRIP AND HANDLING OF THE VEHICLE.**

**SOME TYRE TYPES APPROVED FOR THIS VEHICLE FEATURE WEAR INDICATORS.**

**THERE ARE SEVERAL TYPES OF WEAR INDICATORS. CONSULT YOUR DEALER ON METHODS TO CHECK FOR WEAR.**

**CARRY OUT A VISUAL INSPECTION FOR TYRE WEAR AND TEAR, REPLACE TYRES WHEN WORN.**

**WHEN TYRES ARE OLD, THE MATERIAL MAY HARDEN AND NOT PROVIDE ADEQUATE ROAD HOLDING, EVEN IF TYRES ARE STILL WITHIN THE WEAR LIMIT. REPLACE TYRES IF THIS OCCURS. REPLACE THE TYRE IF IT IS WORN OR IF THERE IS A PUNCTURE LARGER THAN 5 mm (0.197 in) IN THE TREAD AREA.**

**THE WHEELS MUST BE BALANCED AFTER A TYRE IS MENDED.**

**USE ONLY TYRE SIZES INDICATED BY THE MANUFACTURER. DO NOT FIT TYRES WITH INNER TUBES ON RIMS FOR TUBELESS TYRES OR VICE VERSA. CHECK THAT THE INFLATION VALVES HAVE THEIR CAPS FITTED TO AVOID UNEXPECTED FLAT TYRES.**

**REPLACEMENT, MAINTENANCE AND BALANCING OPERATIONS ARE HIGHLY IMPORTANT AND SO THEY SHOULD BE CARRIED USING THE SPECIFIC TOOLS AND WITH ADEQUATE EXPERTISE. HAVE YOUR TYRES AND WHEELS SERVICED AT AN AUTHORISED DEALER OR A SPECIALISED TYRE WORKSHOP.**

**NEW TYRES MAY BE COATED WITH AN OILY FILM: RIDE WITH CAUTION DURING THE FIRST KILOMETRES. DO NOT APPLY UNSUITABLE LIQUIDS ON TYRES.**

#### Minimum tread depth:

front and rear 2 mm (0.079 in) (USA 3 mm) (USA 0.118 in) and anyway not lower to what it is specified in the current legislation in the country in which the vehicle is used.

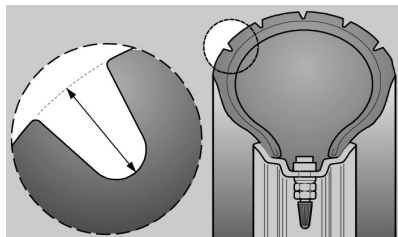

**(if applicable)**

The vehicle is equipped with TPMS sensors (Tyre Pressure Measurement System) located on the inside of the rims near the

inflation valves; they communicate the tyre pressure to the digital display via radio frequency.

A screen can be viewed on the digital display where the reference values and any warning signals (if active) are constantly visible.

Possible warnings are accompanied by the fixed lighting of the TPMS icon, visible both in the various driving modes and in the NAVI mode.



When replacing tires, pay close attention to the following information:

- The bead breaking of the tyre must take place at a distance of at least 90° from the inflation valve.
- The positioning of the levers for the removal of the tyre must be at a distance of at least 10 cm (3.93 in) from the inflation valve.

**N.B.:**



WITH EACH KEY "ON", THE TPMS ICON WILL FLASH UNTIL THE SYSTEM DETECTS A VALID SIGNAL FROM BOTH SENSORS. THE FLASHING CAN LAST UP TO THREE MINUTES.

## Spark plug removal

### WARNING



FOR REMOVAL, CHECK, AND REPLACEMENT OF THE SPARK PLUGS CONTACT AN OFFICIAL Moto Guzzi Dealer.

## Air filter removal

### WARNING



TO REMOVE, CHECK AND REPLACE THE AIR FILTER, CONTACT AN Official Moto Guzzi Dealer.

## Coolant level

Do not use the vehicle if the coolant level is below the minimum marking.

### CAUTION



COOLANT IS TOXIC IF INGESTED; CONTACT WITH YOUR EYES OR SKIN MAY CAUSE IRRITATION. IF THE FLUID GETS IN CONTACT WITH THE EYES OR SKIN, RINSE REPEATEDLY WITH PLENTY OF WATER AND SEEK MEDICAL ADVICE.

IF SWALLOWED, INDUCE VOMITING, RINSE THE MOUTH AND THROAT WITH PLENTY OF WATER AND SEEK MEDICAL ADVICE IMMEDIATELY.

### CAUTION



NEVER UNDO THE RADIATOR CAP WHEN THE ENGINE IS WARM, AS THE COOLANT IS PRESSURISED AND VERY HOT. CONTACT WITH SKIN OR CLOTHES MAY CAUSE SEVERE BURNS AND/OR INJURIES.

## Checking the coolant

- Shut off the engine and wait until it cools off.
- Keep the vehicle upright with both wheels on a flat surface.
- Looking from right side of the vehicle, behind the front fork, make sure that

the fluid level in the expansion tank is between the reference marks (1) "MAX" and (2) "MIN".

- Top up immediately if the fluid level is below the "MIN" level.

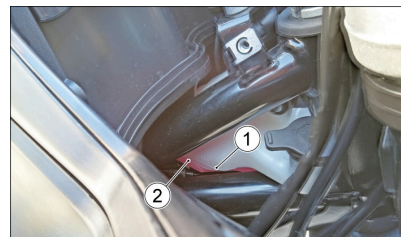

## Top up coolant

- With the engine stopped and cold, remove the cap from the expansion tank and add coolant to bring the level between the (1) "MAX" and (2) "MIN" reference marks.

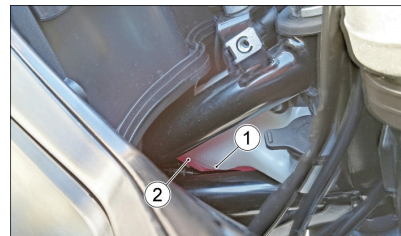

### CAUTION



**CARRY OUT THE CHECK AND TOP UP THE REFRIGERANT LIQUID WITH THE ENGINE SWITCHED OFF AND COLD.**

#### WARNING



**TO REPLACE THE COOLANT, CONTACT AN Official Moto Guzzi Dealer.**

## Brake fluid level check

### Front brake fluid check

- Keep the vehicle upright so that the fluid in the reservoir is at the same level as the plug.
- Check that the fluid in the tank is between the marks (1) and (2).

**(1): MIN** = minimum level

**(2): MAX** = maximum level

If the fluid does not reach at least the "**MIN**" reference mark:

- Check the brake pads and discs for wear.

If the brake pads and/or brake discs do not have to be replaced, have the braking

system checked at an **Official Moto Guzzi Dealership**.

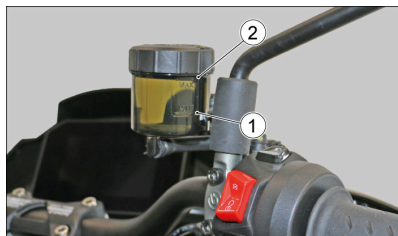

#### WARNING



**FLUID LEVEL DECREASES GRADUALLY AS BRAKE PADS WEAR DOWN.**

### Rear brake fluid check

- Keep the vehicle upright so that the fluid in the reservoir is at the same level as the plug.
- Check that the fluid in the tank is between the marks (1) and (2).

**(1): MIN** = minimum level

**(2): MAX** = maximum level

If the fluid does not reach at least the "**MIN**" reference mark:

- Check the brake pads and disc for wear.

If the brake pads and/or brake disc do not have to be replaced, have the braking system checked at an **Official Moto Guzzi Dealership**.

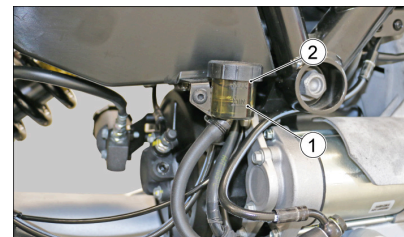

#### WARNING



**FLUID LEVEL DECREASES GRADUALLY AS BRAKE PADS WEAR DOWN.**

### Topping up brake fluid

#### WARNING



**FOR THE TOP-UP OF THE BRAKING SYSTEMS COOLANT, CONTACT AN Official Moto Guzzi Dealer.**

## Clutch fluid level check

### Clutch fluid level check

- Keep the vehicle upright so that the fluid in the reservoir is at the same level as the plug.
- Check that the fluid in the tank is between the marks (1) and (2).

(1): **MIN** = minimum level

(2): **MAX** = maximum level

If the fluid does not reach the "**MIN**" reference, have the clutch system checked by an **Official Moto Guzzi dealer**.

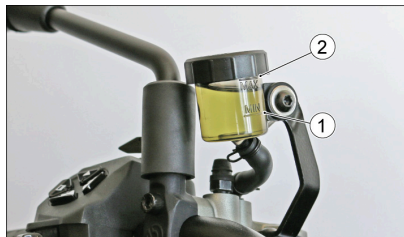

### Clutch fluid top-up

#### WARNING



**FOR THE TOP-UP OF THE CLUTCH FLUID, CONTACT AN Official Moto Guzzi Dealer.**

## Battery

### Battery removal

- Make sure the ignition switch is set to "KEY OFF";
- Remove the rider saddle;
- Disconnect the connector (1) of the OBD2 socket;
- Remove the cable (2) of the GMP provision, moving it forward to release it from its support;

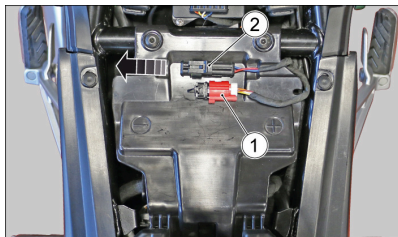

- Remove the two fixing screws (3);

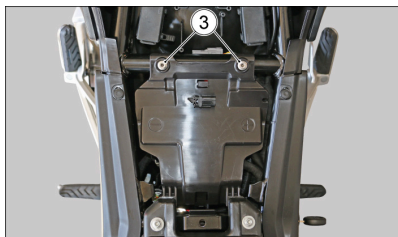

- Release the plastic securing the battery from its mountings to the tank and

remove it by bringing it toward the rear of the vehicle.

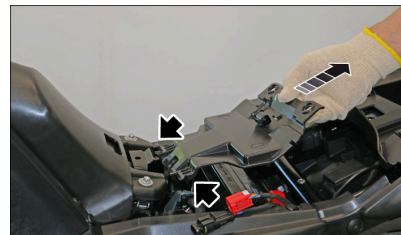

- Unscrew and remove the screw (4) from the negative terminal (-).
- Move the negative lead (5) aside.
- Move the protection cap (6), unscrew and remove the screw (7) from the positive terminal (+).
- Move the positive lead (8) aside.
- Grip the battery firmly and remove from its seat.
- Put the battery away on a level surface, in a cool and dry place.

#### WARNING



**CHECK THAT THE CABLE TERMINALS AND BATTERY LEADS ARE:**

- **IN GOOD CONDITION (NOT CORRODED OR COVERED BY DEPOSITS);**

- COVERED BY NEUTRAL GREASE OR PETROLEUM JELLY.

N.B.:



REMOVING THE BATTERY RESETS THE DIGITAL CLOCK AND THE TRIP JOURNAL FUNCTIONS.

#### CAUTION



ONCE REMOVED, THE BATTERY MUST BE PUT AWAY IN A SAFE PLACE OUT OF THE REACH OF CHILDREN.

#### WARNING



UPON REFITTING, CONNECT THE LEAD TO THE POSITIVE TERMINAL (+) FIRST AND AFTERWARDS THE LEAD TO THE NEGATIVE TERMINAL (-).

#### Electrolyte level check

N.B.:



THIS VEHICLE IS FITTED WITH A MAINTENANCE-FREE BATTERY AND DOES NOT NEED ANY INTERVENTION, EXCEPT FOR SPORADIC CHECKS AND RECHARGE.

#### Charging the battery

- Remove the battery.
- Get an adequate battery charger.
- Set the battery charger for the recharge type indicated.
- Connect the battery to the battery charger.

#### CAUTION



WHEN RECHARGING OR USING THE BATTERY, BE CAREFUL TO HAVE THE ROOM ADEQUATELY AIRED. DO NOT BREATHE GASES RELEASED WHEN THE BATTERY IS RECHARGING.

- Switch on the battery charger.

#### CHARGE MODES

##### Normal recharge

- Electric current: 1,4 A
- Time: 5-10 hours

##### Quick charge

- Electric current: 6 A
- Time: 1 hours

##### Prolonged inactivity

If the vehicle is inactive longer than fifteen days, it is necessary to recharge the battery to avoid sulphation.

- Remove the battery and put it away in a cool and dry place.

In winter or when the vehicle is out of use for prolonged periods, check charge level frequently (about once a month) to prevent deterioration.

- Recharge it fully with an ordinary charge.

If the battery is still on the vehicle, disconnect the cables from the terminals.

##### Checking and cleaning terminals and leads

- Partially remove the battery from its housing.
- Check that the battery cable terminals and leads are in good conditions (not corroded or covered by deposits) and covered with neutral grease or petroleum jelly.

#### Fuses

**WARNING**



**DO NOT ATTEMPT TO REPAIR FAULTY FUSES.**

**NEVER USE A FUSE THAT IS DIFFERENT THAN WHAT IS SPECIFIED TO PREVENT DAMAGES TO THE ELECTRICAL SYSTEM OR SHORT CIRCUITS, AND THE RISK OF FIRE.**

**WARNING**



**A FUSE THAT BLOWS FREQUENTLY MAY INDICATE A SHORT CIRCUIT OR OVERLOAD. IF THIS OCCURS, CONTACT AN Official Guzzi Dealer.**

- Set the ignition switch to 'OFF' to avoid an accidental short circuit;
- Remove the passenger saddle;
- Remove the fuse box cover;
- Take out one fuse at a time and check if the filament is broken;
- Before replacing the fuse, find and solve, if possible, the reason that caused the problem;
- If the fuse is damaged, replace it with one of the same current rating.

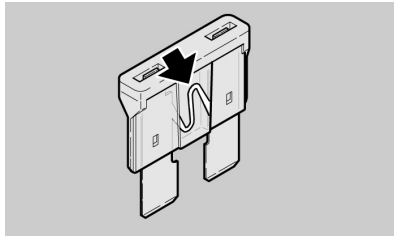

**N.B.:**



**IF THE SPARE FUSE IS USED, REPLACE WITH ONE OF THE SAME TYPE IN THE CORRESPONDING FITTING.**

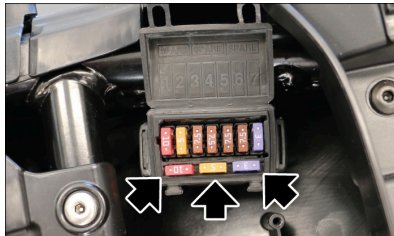

**MAIN FUSES**

- They are located under the tank, in front of the E.C.U.
- **If there is a problem with the main fuses, DO NOT replace them, but take**

**your vehicle to an Official Moto Guzzi dealer.**

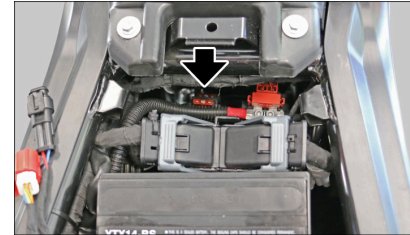

**MAIN FUSES**

40A fuse	Charging the battery
30A fuse	Loads of the entire vehicle

spare fuses

**SECONDARY FUSES**

- They are located on the tail fairing, under the rider saddle.

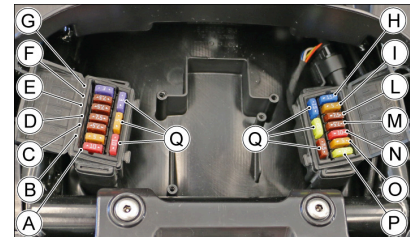

AUXILIARY FUSES (1)		
A) 10A fuse	Rear position, Horn licence plate light	
B) 5A fuse	Fog lights live positive lead (if applicable)	
C) 7.5A fuse	Key-on positive ECU  Key-on positive ABS  Key-on positive instrument cluster  Key-on positive right light switch,  Key-on positive inertial platform,  Key-on positive stand  Key-on positive TPMS (where required)  Key-on positive rear radar (where required)  Main starter relay	
D) 7.5A fuse	Key-on positive electronic	

AUXILIARY FUSES (1)		
		suspensions (where required)
E) 7.5A fuse	Key-on positive GMP (where required)  Key-on positive OBD2  Key-on positive theft protection	
F) 7.5A fuse	Headlamp key-on positive	
G) 3A fuse	USB 1 and 2 key- on positive (2 if provided)	
Q) Spare fuses		
AUXILIARY FUSES (2)		
H) 15A fuse	Power supply for: Fan relay ECU, Fuel pump relay lambda probe right and left injectors right and left, coils right and left,	

AUXILIARY FUSES (2)	
	Secondary air valve Purge valve
I) 5A fuse	Power supply for: Pre-installation for anti-theft device OBD2, Front radar (where required)
L) 7.5A fuse	Fan power feed
M) 7.5A fuse	ECU permanent positive lead
N) fuse of 10A	MGCA aerodynamic protection power supply
O) 5A fuse	Instrument panel power supply (turn indicators)
P) 20A fuse	ABS power feed
Q) Spare fuses	

## Front light cluster

The headlamp unit uses LED light sources only, and consists of the following modules:

- two low beam headlight modules (1);

- one high beam headlight module (2);
- A DRL / position module (with low beam switched on) (3);
- two bending light modules (to assist rider in bends) (4).

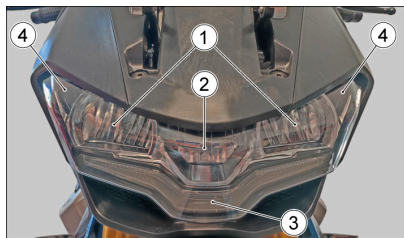

**N.B.:**



**WHEN THE REAR WHEEL EXCEEDS THE SPEED OF 1 km/h (0.62 mph) (EVEN WITH THE ENGINE OFF, AND THE KEY SET TO ON), THE HEADLIGHTS WILL TURN ON AND WILL REMAIN ON FOR 30 SECONDS (FROM THE TIME IN WHICH THE REAR WHEEL STOPS MOVING).**

The 'bending light' modules (4) are activated when the vehicle reaches or exceeds a 25 degree angle when cornering, and only when the low beam is switched on.

- When leaning into a right hand turn, the right hand LED bending assist light illuminates (A).

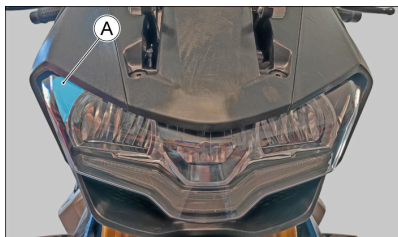

- When leaning into a left hand turn, the left hand LED bending assist light illuminates (A).

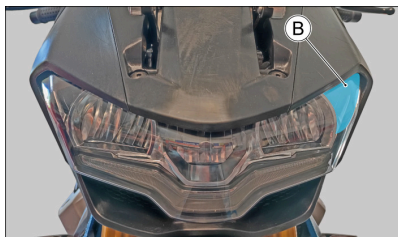

**WARNING**



**TO REMOVE, CHECK AND REPLACE THE FRONT LIGHT ASSEMBLY LAMPS, CONTACT AN Authorised Moto Guzzi Dealership.**

**Headlight adjustment**

**N.B.:**



**IN COMPLIANCE WITH LOCAL LEGAL REQUIREMENTS, SPECIFIC PROCEDURES MUST BE FOLLOWED WHEN CHECKING LIGHT BEAM ADJUSTMENT.**

**For a quick check of the correct direction of the front light beam:**

- Place the vehicle 10 m (32.81 ft) away from a vertical wall and make sure the ground is level.
- Place the vehicle in a vertical position;
- Turn on the low beam light, sit on the vehicle and check that the light beam projected to the wall is a little below the headlight horizontal straight line (about 9/10 of the total height).

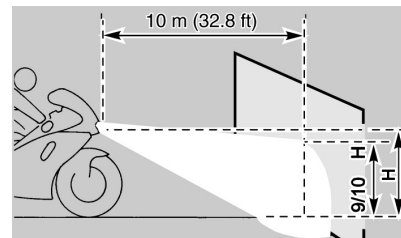

### In order to carry out the vertical adjustment of the light beam:

- Position the vehicle upright and ensure its stability;
- Adjust the adjusting screws (1) and (2), located under the instrument panel, to adjust the (1) left and (2) right **low beam** headlamps. Turning the screw clockwise lowers the headlamp, and counterclockwise raises the headlamp.

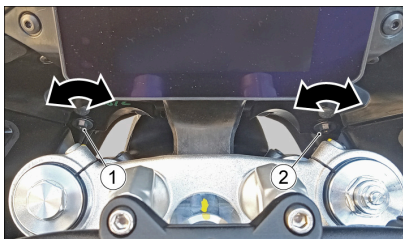

- Using a Phillips screwdriver, turn the adjustment screw that can be reached from under the top fairing to adjust the high beam headlight. Turning the screw clockwise lowers the headlamp, and counterclockwise raises the headlamp.

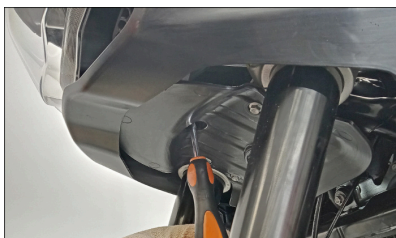

### Front turn indicators

#### WARNING



**TO REMOVE, CHECK AND REPLACE THE FRONT TURN INDICATORS, PLEASE CONTACT AN Authorised Moto Guzzi Dealership.**

### Rear light assembly

#### WARNING



**TO REMOVE, CHECK AND REPLACE THE REAR LIGHT ASSEMBLY, CONTACT AN Authorised Moto Guzzi Dealership.**

### Rear turn indicators

#### WARNING



**TO REMOVE, CHECK AND REPLACE THE REAR TURN INDICATORS, PLEASE CONTACT AN Authorised Moto Guzzi Dealership.**

### Rear-view mirrors

#### CAUTION



**DO NOT RIDE WITH REAR-VIEW MIRRORS INCORRECTLY SET.**

**ALWAYS CHECK THAT THE MIRRORS ARE ADJUSTED CORRECTLY BEFORE SETTING OFF.**

#### Removing the rear-view mirrors:

- Rest the vehicle on its stand.
- Lift the rubber protection (1).
- Loosen the fastening nut (2) by ensuring that the threaded clamp (3) cannot rotate.
- Slide up and remove the complete rear-view mirror unit (4).

Repeat the procedure to remove the other rear-view mirror, if necessary.

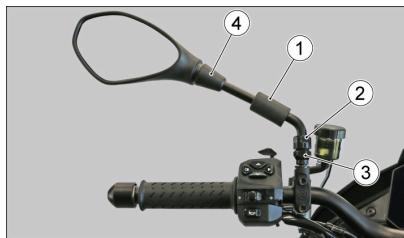

#### CAUTION



**UPON REFITTING AND BEFORE TIGHTENING THE LOCKING NUT, MAKE SURE THAT THE REAR VIEW MIRROR SUPPORT STEM IS ALIGNED WITH THE HANDLEBAR.**

#### CAUTION



**THE VEHICLE MAY NOT BE RIDDEN ON PUBLIC ROADS WITH THE REAR VIEW MIRRORS REMOVED.**

**Rear-view mirrors adjustment:**

- Get onto the bike in the riding position.

- Turn the mirror, correctly adjusting the inclination.
- Repeat the procedure to adjust the other mirror.
- Make sure there is no dirt or mud.

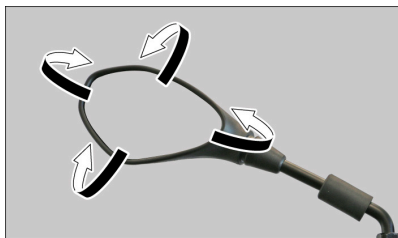

### Front and rear disc brake

Do not ride your vehicle with worn or malfunctioning brakes! Brakes are one of the most important parts for your vehicle's safety system, and using a vehicle that does not have perfect brakes means you are at high risk of collisions and accidents, even fatal.

#### CAUTION



**A DIRTY DISC SMEARS THE PADS RESULTING IN POOR BRAKING.**

**REPLACE DIRTY PADS AND CLEAN AGAIN THE DIRTY DISC USING A TOP QUALITY DEGREASING PRODUCT.**

#### WARNING



**TAKE YOUR VEHICLE TO AN Official Moto Guzzi Dealer TO HAVE THE FRONT WHEEL REMOVED.**

#### CAUTION



**IN CONDITIONS OF HUMID AND WET GROUND, THE PERFORMANCE OF THE BRAKING SYSTEM IS WIDELY REDUCED.**

**WHEN THE ROAD SURFACE IS WET DUE TO RAIN, YOU SHOULD CHOOSE TO MAINTAIN A DOUBLE SAFETY DISTANCE, ALSO BECAUSE THE TYRE GRIP TO THE GROUND IS EXTREMELY REDUCED. PAY UTMOST ATTENTION TO WATER THAT CAN COME INTO CONTACT WITH THE BRAKES AFTER YOU HAVE WASHED YOUR VEHICLE, OR AFTER PASSING THROUGH PUDDLES ON THE ROAD, AS IT CAN SUFFICIENTLY WET YOUR BRAKING SYSTEM AND THEREFORE CONSIDERABLY REDUCE THEIR PERFORMANCE.**

**FAILURE TO OBSERVE THIS WARNING CAN LEAD TO SERIOUS ACCIDENTS AND EVEN DEATH.**

Your vehicle is equipped with disc brakes with separate braking systems.

The front braking system is equipped with two discs, one on the right side and the other on the left side of the front wheel. The rear braking system is equipped with a single disc located on the left side of the rear wheel. The following information may refer to a single braking system but is valid for both braking systems.

#### CAUTION



**BRAKES ARE EXTREMELY IMPORTANT FOR YOUR SAFETY. DO NOT USE YOUR VEHICLE IF THE BRAKES ARE NOT WORKING PERFECTLY. ALWAYS CHECK THE EFFICIENCY OF THE BRAKES BEFORE RIDING THE VEHICLE.**

#### CAUTION



**IF THE POSITION OF THE BRAKE LEVER CHANGES, IT MAY BE DUE TO**

**A PROBLEM WITH THE HYDRAULIC SYSTEM. FOR ANY DOUBT ABOUT THE PERFECT OPERATION OF THE BRAKES AND FOR THE NORMAL PERIODIC CHECK, CONTACT A Moto Guzzi Official Dealer BEFORE RIDING THE VEHICLE.**

**PAY UTMOST ATTENTION TO THE BRAKE DISCS AND THE FRICTION CAPACITY, MAKING SURE THEY ARE NOT DIRTY AND OILY, ESPECIALLY AFTER MAINTENANCE OR INSPECTION OPERATIONS. CHECK THAT THE BRAKE PIPES ARE NOT GLAZED OR TWISTED, AND THAT THERE IS NO LEAKAGE.**

**KEEP BRAKE FLUID OUT OF THE REACH OF CHILDREN. DISPOSE OF BRAKE FLUID CORRECTLY.**

#### CAUTION



**CHECK BRAKE PADS FOR WEAR MAINLY BEFORE EACH RIDE.**

**To perform a quick pad wear check:**

- Rest the vehicle on its stand.
- Carry out a visual inspection of brake disc and pads as follows:

- from the top rear side to check the front brake callipers (1);

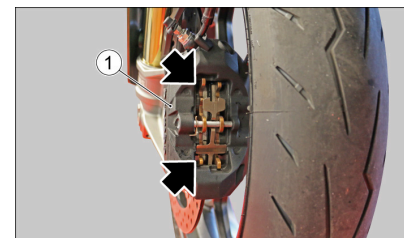

- from the bottom rear side to check the rear brake calliper (2).

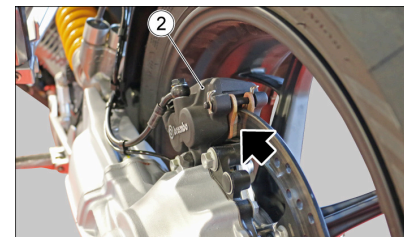

#### CAUTION



**EXCESSIVE WEAR OF THE FRICTION MATERIAL MAKES THE PAD METAL SUPPORT GET INTO CONTACT WITH THE DISC, WHICH RESULTS IN A METALLIC NOISE AND SPARKS IN THE CALLIPER; THEREFORE, BRAKING EFFICIENCY AND DISC SAFETY AND INTEGRITY ARE AT RISK.**

If the thickness of the friction material (even just one front or rear pad) is reduced to a value of about **1.5 mm (0.059 in)** (or even if just one of the wear indicators is no longer visible), contact an **Official Moto Guzzi Dealer** to replace all the brake pads.

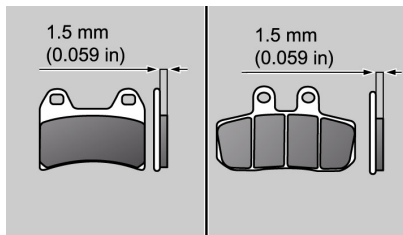

## vehicle inactivity

A number of precautionary measures must be taken to prevent the possible consequences of prolonged lack of usage of the vehicle. Besides, it is necessary to carry out general repairs and checks before garaging the motorcycle as one can forget to do so afterwards.

Proceed as follows:

- Remove the battery.
- Wash and dry the motorcycle.
- Apply wax polish to painted and chromed surfaces.
- Inflate the tyres.
- Store the motorcycle in a cool, dry place, not exposed to sun rays and with minimum temperature variations.

- Wrap and tie a plastic bag around the exhaust pipe opening to keep moisture out.
- Cover the vehicle but do not use plastic or waterproof materials.

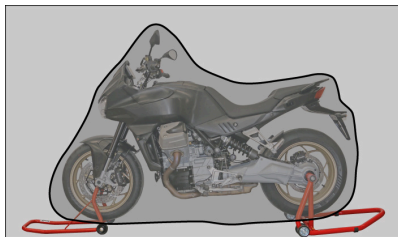

### WARNING



**PLACE THE VEHICLE ON SUITABLE SUPPORTS TO KEEP THE TYRES OFF THE GROUND.**

### CAUTION



**TO AVOID BATTERY DETERIORATION, FOLLOW THE OPERATIONS DESCRIBED FOR PROLONGED INACTIVITY.**

## AFTER STORAGE

- Uncover and clean the vehicle.
- Check the battery for correct charge and install it.
- Refill the fuel tank.
- Carry out the pre-ride checks.

**N.B.:**



**TAKE THE PLASTIC BAGS OFF THE EXHAUST PIPE OPENING.**

**N.B.:**



**AS A TEST, RIDE THE MOTORCYCLE FOR A FEW KILOMETRES AT A MODERATE SPEED AND AWAY FROM TRAFFIC AREAS.**

## Vehicle cleaning

Moto Guzzi recommends using quality products for cleaning the vehicle. The use of unsuitable products can damage vehicle components. For cleaning do not use solvents such as "nitro thinner", "cold cleaning agents", or similar fuels, or cleaning products that contain alcohol.

## WASHING THE MOTORCYCLE

Moto Guzzi recommends softening with water and then carefully removing the insects and stubborn stains before washing the vehicle.

To prevent stains, do not wash the motorcycle immediately after exposure to sunlight, and do not wash it in the sun.

If the vehicle is used during the winter months, be sure to frequently wash the motorcycle. To remove anti-icing salt sprayed on roads in the winter, wash the motorcycle with cold water immediately after use.

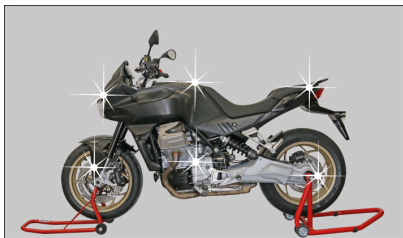

### WARNING



**USE OF HOT WATER INTENSIFIES THE EFFECT OF THE SALT. USE ONLY PLENTY OF COLD WATER TO WASH AND REMOVE ANTI-ICING SALT.**

### WARNING



**USE OF HIGH PRESSURE WASHING SYSTEMS (OR STEAM CLEANERS) CAN DAMAGE THE SEALS, OIL SEALS, BRAKING SYSTEM, ELECTRICAL SYSTEM AND THE SADDLE. DO NOT USE STEAM OR HIGH PRESSURE CLEANING SYSTEMS. DO NOT USE STEAM OR HIGH PRESSURE WASHING SYSTEMS. DO NOT INSIST WITH THE PRESSURE NOZZLE ON THE STEERING BEARING, WHEEL BEARINGS, INSIDE THE REAR WHEEL HUB, ON THE HYDRAULIC BRAKING CIRCUIT AND ON THE ELECTRICAL PARTS.**

## CLEANING OF SENSITIVE PARTS

### BODYWORK

To keep the motorcycle bright, wash it regularly, especially if used in areas with high levels of pollution or mud. Aggressive stains from tree resins, gasoline, oil, brake fluid or bird excrement in general.

must be removed immediately, otherwise permanent stains on the paint can appear. After washing is easy to identify marks and residual stains, remove these from the bodywork using a soft cloth, of a non-abrasive polish brand. Periodic care,

a thorough cleaning of the bodywork preserves the aesthetic quality of the motorcycle over the long term.

## PLASTIC COMPONENTS

### WARNING



**IF THE PLASTIC COMPONENTS ARE CLEANED USING AGGRESSIVE AGENTS, THE SURFACE MAY BE DAMAGED. DO NOT USE CLEANING PRODUCTS CONTAINING ALCOHOL, SOLVENTS OR THAT ARE ABRASIVE FOR THE CLEANING OF PLASTIC PARTS. ROTARY BRUSHES OR SPONGES WITH HARD SURFACES CAN MAKE SCRATCHES.**

## FRONT HEADLIGHT

Do not use products containing aggressive agents during use or during washing, due to the structure of the bottom bracket cup, under the frame can be detected water or dirt.

Since water outside the headlight will dry due to the heat and ventilation during use of the motorcycle, in case of persistence use compressed air at a distance of 10 cm from the headlight.

### WARNING



TO CLEAN THE HEADLIGHTS USE A SPONGE SOAKED IN WATER AND MILD DETERGENT, RUBBING THE SURFACE GENTLY AND RINSING FREQUENTLY WITH PLENTY OF WATER.

DO NOT POLISH MATT-PAINTED SURFACES WITH POLISHING PASTE.

THE VEHICLE SHOULD NEVER BE WASHED IN DIRECT SUNLIGHT, ESPECIALLY DURING SUMMER, OR WITH THE BODYWORK STILL HOT AS THE CAR SHAMPOO CAN DAMAGE THE PAINTWORK IF IT DRIES BEFORE BEING RINSED OFF.

N.B.:



AFTER HEAVY RAIN, WASHING OR IN CASE OF RAPID TEMPERATURE CHANGES, THE LENSES OF THE FRONT LIGHT ASSEMBLY MAY BECOME FOGGY.

THIS STATE IS DUE TO THE TEMPERATURE DIFFERENCE BETWEEN THE OUTSIDE AND THE INSIDE AND DOES NOT INDICATE A FAULT OF THE FRONT LIGHT ASSEMBLY.

## CHROME PARTS AND POLISHED METAL

### WARNING



TREAT THE PARTS MADE OF CHROME, ALUMINIUM OR POLISHED STEEL IN A SPECIAL MANNER. WASH THEM WITH PLENTY OF WATER AND CAR SHAMPOO, POLISH AND REGULARLY BRIGHTEN THEM WITH POLISH PASTE, PROTECT THEM WITH WAXES OR SUITABLE ACID-FREE PRODUCTS (E.G. VASELINE).

### RUBBER PARTS

Clean the rubber parts using water and mild shampoo (brand-name, suitable for car bodies)

### WARNING



THE USE OF SILICONE SPRAY TO CLEAN THE RUBBER SEALS MAY CAUSE DAMAGE. DO NOT USE OTHER PRODUCTS CONTAINING SILICON FOR CLEANING THE MOTORCYCLE.

Clean the motorcycle frequently if exposed to adverse conditions, such as:

- Air pollution (cities and industrial areas).
- Salinity and humidity in the atmosphere (seashore areas, hot and wet weather).
- Special environmental/seasonal conditions (use of salt, anti-icing chemical products on the roads in winter).
- Always clean off any smog and pollution residue, tar stains, insects, bird droppings, etc. from the bodywork.
- Avoid parking the vehicle under trees. In some seasons, in fact, residues, resins, fruits or leaves may fall from the trees, containing chemicals that are harmful to the paintwork.

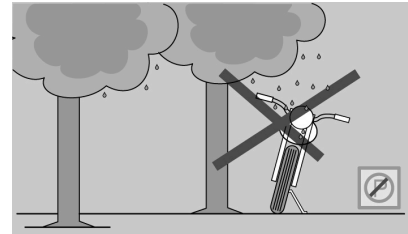

### WARNING



**BEFORE WASHING THE VEHICLE, COVER THE ENGINE AIR INTAKES AND THE EXHAUST PIPES.**

**WARNING**



**CLEAN THE INSTRUMENT PANEL WITH A SOFT CLOTH MOISTENED WITH WATER.**

**CAUTION**



**AFTER CLEANING YOUR VEHICLE, BRAKING EFFICIENCY MAY BE TEMPORARILY AFFECTED DUE TO THE PRESENCE OF WATER ON THE FRICTION SURFACES OF THE BRAKING CIRCUIT.**

**ALLOW LONGER BRAKING DISTANCES TO PREVENT ACCIDENTS.**

**BRAKE REPEATEDLY TO RESTORE NORMAL OPERATION.**

**CARRY OUT THE PRE-RIDE CHECKS.**

To remove dirt and mud accumulated on painted surfaces, wet the soiled areas thoroughly with a low-pressure water jet, then remove dirt and mud with a soft car body sponge soaked abundantly in a solution of car body shampoo in water (2 - 4% shampoo dissolved in water). Then rinse with plenty of water, and dry with a chamois leather. To clean the engine outer parts, use degreasing detergent, brushes and old cloths. Wash anodised or painted aluminium parts with neutral soap and water. Using aggressive detergents may damage the surface treatment of these components.

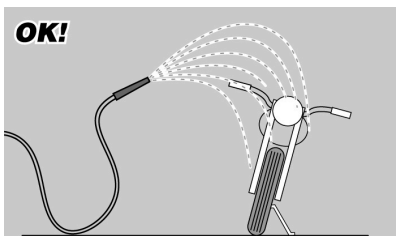

**WARNING**



**NEVER USE CLOTHS SOAKED IN PETROL, DIESEL OIL OR KEROSENE FOR CLEANING THE PAINTED OR PLASTIC SURFACES SO AS NOT TO DAMAGE THE LUSTRE**

**FINISH OR ALTER THE MECHANICAL PROPERTIES.**

**WARNING**



**DO NOT USE WATER (OR LIQUIDS) AT TEMPERATURES OVER 40°C (104°F) WHEN CLEANING THE VEHICLE PLASTIC PARTS. DO NOT USE HIGH-PRESSURE AIR OR WATER JETS OR STEAM JETS.**

**DO NOT USE ALCOHOL OR SOLVENTS TO CLEAN ANY RUBBER OR PLASTIC SADDLE COMPONENTS USE WATER AND MILD SOAP.**

**WARNING**



**DO NOT USE SOLVENTS OR PETROL BY-PRODUCTS (ACETONE, TRICHLOROETHYLENE, TURPENTINE, PETROL, THINNERS) TO CLEAN THE SADDLE. USE INSTEAD DETERGENTS WITH SURFACE ACTIVE AGENTS NOT EXCEEDING 5% (NEUTRAL SOAP, DEGREASING DETERGENTS OR ALCOHOL).**

DRY THE SADDLE WELL AFTER CLEANING.

THE USE OF WAX OR SIMILAR PRODUCTS COMPROMISES THE SAFETY OF THE SADDLE ITSELF.

#### WARNING



WHEN USING A SYSTEM OF PRESSURE WASHING (AFTER CHECKING THAT ANY DETERGENTS ARE COMPATIBLE WITH THE MOTORCYCLE FINISH), KEEP A DISTANCE OF AT LEAST ONE METRE.

#### WARNING



CLEAN THE VEHICLE IMMEDIATELY WITH COLD WATER AFTER RIDING ON A ROAD TREATED WITH SALT: SALT IS HIGHLY CORROSIVE.

## Transport

#### CAUTION



BEFORE TRANSPORTING THE VEHICLE, CAREFULLY EMPTY THE FUEL TANK AND CHECK THAT IT IS COMPLETELY DRY.

DURING TRANSPORT, THE VEHICLE SHOULD BE UPRIGHT AND SECURELY ANCHORED AND SHOULD HAVE THE FIRST GEAR ENGAGED SO AS TO AVOID POSSIBLE FUEL, OIL OR COOLANT LEAKS.

IN CASE OF FAILURE, DO NOT TOW THE VEHICLE BUT CONTACT A ROAD ASSISTANCE SERVICE INSTEAD TO HAVE THE INFLAMMABLE FLUIDS DRAINED.

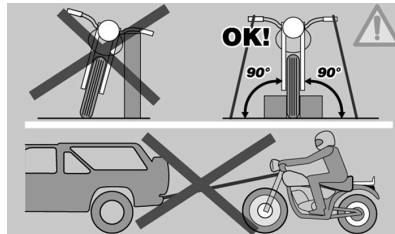

# V100 Mandello - V100 Mandello S



**CHAPTER 05**  
**Technical data**

## Data

Dimensions and mass	
Maximum Length	2125 mm (83.66 in)
Maximum width	835 mm (32.87 in)
Height (adjustable at the windshield)	1210 - 1300 mm (47.63 - 51.18 in)
Wheelbase	1475 mm (58.07 in)
Kerb weight	233 kg (513.68 lb)
Engine	
Type	Four-stroke, 90° transverse V-twin
Number of cylinders	2
Engine capacity	1042 cc (63.59 cu in)
Bore / stroke	96 x 72 mm (3.77 x 2.83 in)
Compression ratio	12.6 ± 0.5 : 1
Ignition	Electric
Idle engine speed	1400 +/- 100 rpm

Engine	
Clutch	Multi plate wet clutch with anti-judder function.
Lubrication system	pressure-fed, controlled by valves and trochoidal pump
Cooling	Liquid
Air filter	cartridge-type dry filter
Capacity	
Fuel tank capacity (including reserve)	17 l (3.74 UK gal; 4.49 US gal)
Fuel tank reserve capacity	3.5 +/- 0.5 l (0.77 +/- 0.11 UK gal; 0.92 +/- 0.13 US gal)
Engine oil	Oil change and oil filter replacement: 4900 cc in (299.02 cu in)
Bevel gear set oil	250 cm <sup>3</sup> (15.26 cu in)
Bevel gear oil (in case of replacement)	225 cc (13.73 cu in) MAX

Capacity	
Seats	2
Max. vehicle load	443 kg (976.64 lb) (rider + passenger + luggage)
Drive ratios	
Primary drive	with gears, ratio: 31/48 = 1 : 1,548
Drive ratio 1st gear	14 / 37 = 1 : 2.642
Drive ratio 2nd gear	17 / 33 = 1 : 1,941
Drive ratio 3rd gear	20 / 31 = 1 : 1,55
Drive ratio 4th gear	22 / 28 = 1 : 1,272
Drive ratio 5th gear	24 / 26 = 1: 1,083
Drive ratio 6th gear	25 / 24 = 1: 0,96

Drive ratios	
Final drive	with U-joint ratio $12 / 38 = 1 : 3,166$

Power feed	
Type	Electronic injection (Marelli 11MP)
Throttle body	Ø 52 mm (2.05 in)
Fuel	Unleaded gasoline E10 (95 R.O.N.)

Chassis	
Type	high strength tubular steel frame
Steering rake angle	24.7°
Trail	104 mm (4.095 in)

Suspension	
Front (V100 Mandello)	hydraulic telescopic fork, Ø 41 mm (1.61 in)
Rear (V100 Mandello S)	electronically controlled hydraulic telescopic fork,

Suspension	
	diameter 43 mm (1.69 in)
Travel (V100 Mandello)	130 mm (5.11 in)
Travel (V100 Mandello S)	130 mm (5.11 in)
Rear shock absorber	Swingarm in die-cast light alloy with 1 shock absorber with adjustable spring pre-loading and hydraulic brake extension.
Travel (V100 Mandello)	130 mm (5.11 in)
Travel (V100 Mandello S)	130 mm (5.11 in)

Brakes	
Front	two 320 mm (12.59 in) diam. stainless steel floating discs, calliper with 4 32 mm (1.26 in) diam. counteracting plungers
Rear	280 mm (11.02 in) stainless steel disc, floating calliper with

Brakes	
	two 28 mm (1.10 in) diameter pistons
Wheel rims	
Type	die-cast alloy
Front wheel	3.5" x 17"
Rear wheel	6.00" x 17"
Tyres	
Front	120 / 70 ZR17 (58W)
Inflation pressure	2.5 bar (250 kPa) (36.26 PSI)
Rear	190 / 55 ZR17 (75W)
Inflation pressure	2.8 bar (280 Kpa) (40.61 PSI)
Spark plugs	
Standard	NGK LMAR8EI-7
Spark plug electrode gap	0.8 mm (0.031 in)

Spark plugs	
-------------	--

Resistance	7.5 KOhm (MAX)
------------	----------------

ELECTRICAL SYSTEM	
-------------------	--

Battery	12 V – 12 Ah
---------	--------------

Fuses	40- 30 - 20 - 15 (3) - 10 (2) - 7.5 (6) - 5 (3) - 3 A
-------	---

Permanent magnet alternator	12V - 550W
-----------------------------	------------

BULBS	
-------	--

High beam/low beam light	LED
--------------------------	-----

Fog lights	LED
------------	-----

Front DRL	LED
-----------	-----

Turn signal lights	LED
--------------------	-----

Rear running light / brake light	LED
----------------------------------	-----

Dashboard lighting	
--------------------	--

INDICATOR LAMPS	
-----------------	--

Gearbox in neutral	LED
--------------------	-----

INDICATOR LAMPS		
-----------------	--	--

High beam headlight	LED	
---------------------	-----	--

Cruise control warning light	LED	
------------------------------	-----	--

ABS warning light	LED	
-------------------	-----	--

MI warning light	LED	
------------------	-----	--

Turn indicators	LED	
-----------------	-----	--

Overspeed threshold / gear shift warning lights	LED	
---	-----	--

Immobilizer warning light	LED	
---------------------------	-----	--

Fuel reserve	LED	
--------------	-----	--

MGCT warning light	LED	
--------------------	-----	--

General alarm	LED	
---------------	-----	--

Daytime running lights warning light	LED	
--------------------------------------	-----	--

Side stand warning light	LED	
--------------------------	-----	--

### RED DIRECTIVE 2014/53/EU

All radio equipment installed by the manufacturer on this vehicle complies with Directive 2014/53/EU (RED directive). The relative homologation documents are available at the following web address:

[redhomologation.piaggiogroup.com](http://redhomologation.piaggiogroup.com)

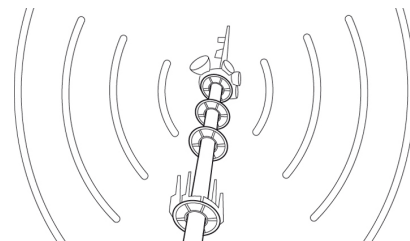

### Toolkit

A 4 mm Allen key is supplied with the vehicle located on the underside of the passenger seat.



# V100 Mandello - V100 Mandello S



## CHAPTER 06 Spare parts and accessories

**Caution****WARNING!**

TO PREVENT ACCIDENTS AND TO GUARANTEE PROPER STABILITY, PERFORMANCE AND SAFETY, RIDE THE VEHICLE VERY CAREFULLY WHEN IT IS FITTED WITH ACCESSORIES OR WITH UNUSUAL LOADS.

**WARNING**

IT IS ALSO RECOMMENDED THAT ORIGINAL PIAGGIO GROUP SPARE PARTS BE USED, AS THESE ARE THE ONLY ONES OFFERING YOU THE SAME QUALITY GUARANTEE AS THOSE INITIALLY FITTED ON THE VEHICLE.

NOTE THAT USING NON-ORIGINAL SPARE PARTS WILL VOID THE WARRANTY.

**WARNING!**

PIAGGIO GROUP SELLS ITS OWN LINE OF ACCESSORIES, WHICH ARE APPROVED FOR USE WITH PIAGGIO VEHICLES AND COVERED BY A PIAGGIO WARRANTY. IT IS THEREFORE ESSENTIAL TO CONTACT A DEALERSHIP OR AN AUTHORISED SERVICE CENTRE IN ORDER TO CHOOSE AND FIT ACCESSORIES CORRECTLY.

USING NON-ORIGINAL ACCESSORIES MAY AFFECT THE STABILITY AND FUNCTIONS OF YOUR VEHICLE, COMPROMISING THE SAFETY OF THE VEHICLE AND EXPOSING THE RIDER TO DANGER.

**WARNING**

BE EXTREMELY CAREFUL WHEN INSTALLING AND REMOVING THE MECHANICAL ANTI-THEFT DEVICE ON THE VEHICLE (U-SHAPED PADLOCK, DISC BLOCK, ETC.).

MAINLY NEAR THE BRAKE PIPES, TRANSMISSIONS AND/OR ELECTRIC CABLES, AN INCORRECT INSTALLATION OR REMOVAL OF

THE ANTITHEFT DEVICE AS WELL AS LEAVING IT ON BEFORE STARTING THE VEHICLE CAN SERIOUSLY DAMAGE ITS COMPONENTS, COMPROMISE THE CORRECT FUNCTIONING OF THE VEHICLE AND USERS' SAFETY.

**CAUTION**

NEVER OPERATE THE VEHICLE WITH ACCESSORIES (BAGS, TOP BOX AND/OR WINDSHIELD) AT A SPEED HIGHER THAN 100 kph.

THE VEHICLE CAN BE RIDDEN AT A HIGHER SPEED WITHOUT THE ACCESSORIES MENTIONED BEFORE WITHIN THE LIMITS ESTABLISHED BY LAW.

IF THERE ARE ANY NON-ORIGINAL ACCESSORIES INSTALLED, OR AN ABNORMAL LOAD, OR IF THE MOTORCYCLE IS NOT IN A GENERALLY GOOD CONDITION, OR WHENEVER WEATHER CONDITIONS DEMAND IT, SPEED SHOULD BE FURTHER REDUCED.

# V100 Mandello - V100 Mandello S



## CHAPTER 07 Scheduled maintenance

## The value of service

As a result of continuous updates and specific technical training programmes for Moto Guzzi products, only **Moto Guzzi** Official Network mechanics know this vehicle fully and have the specific tools necessary to carry out maintenance and repair operations correctly.

The reliability of the vehicle also depends on its mechanical conditions. Checking the vehicle before riding it, its regular maintenance and the use of original Moto Guzzi spare parts only are essential factors!

For information on the nearest **Official Dealer and/or Service Centre** consult our website:

[www.Motoguzzi.com](http://www.Motoguzzi.com)

## Scheduled maintenance

Proper maintenance is a crucial factor in prolonging the durability of the vehicle and keeping it in perfect working order.

### Scheduled maintenance table

Km x 1.000 (mi x 1.000)	1,5 (0.9)	12 (7.5)	24 (14.9)	36 (22.4)	48 (29.8)	60 (37.3)	72 (44.7)	EVERY 12 MONTHS	EVERY 24 MONTHS
Engine oil filler plug O-ring									
Fork plug O-ring									
Spark plugs			R		R		R		
Alternator belt			R		R		R		R

To ensure that maintenance is carried out correctly, the constructor has defined the schedule of checks and services (performed at the owner's expense) summarised in the table given in the following page. It is a good idea to report small performance anomalies right away to an **Authorised Service Centre**, without waiting for the next scheduled service, so they can be repaired immediately.

All scheduled maintenance services must be carried out at the prescribed times, even if the specific mileage has not yet been reached. Services must be performed punctually at the correct intervals to maintain the validity of the warranty. For any additional information concerning Warranty procedures and 'Scheduled Maintenance', please consult the 'Warranty Conditions'.

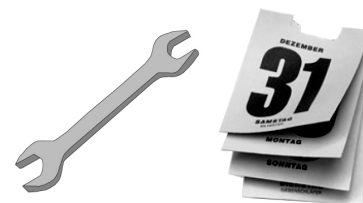

**N.B.:**



**CARRY OUT MAINTENANCE OPERATIONS AT HALF THE INTERVALS SPECIFIED IF THE VEHICLE IS USED IN PARTICULAR RAINY OR DUSTY CONDITIONS, OFF ROAD OR FOR TRACK USE.**

<b>Km x 1.000 (mi x 1.000)</b>	<b>1,5 (0.9)</b>	<b>12 (7.5)</b>	<b>24 (14.9)</b>	<b>36 (22.4)</b>	<b>48 (29.8)</b>	<b>60 (37.3)</b>	<b>72 (44.7)</b>	<b>EVERY 12 MONTHS</b>	<b>EVERY 24 MONTHS</b>
Steering bearings and steering play	I	I	I	I	I	I	I	I	I
Front wheel bearings		I	I	I	I	I	I	I	I
Diagnosis by tool	I	I	I	I	I	I	I	I	I
Brake discs - Pads wear (4)	I	I	I	I	I	I	I	I	I
Air filter		R	R	R	R	R	R		
Engine oil filter	R	R	R	R	R	R	R	R	R
Vehicle general operation	I	I	I	I	I	I	I	I	I
Valve clearance			I		I		I		
Head cover gasket	I	I	I	I	I	I	I		
Engine oil discharge plug aluminium gasket	R	R	R	R	R	R	R	R	R
Transmission oil discharge plug gasket			R		R		R		
Engine oil filter cover O-ring	R	R	R	R	R	R	R	R	R
Brake systems	I	I	I	I	I	I	I	I	I
Light circuit	I	I	I	I	I	I	I	I	I
Safety switches	I	I	I	I	I	I	I	I	I
Brake fluid	I	I	I	I	I	I	I	I	R
Clutch fluid	I	I	I	I	I	I	I	I	R

## 7 Scheduled maintenance

Km x 1.000 (mi x 1.000)	1,5 (0.9)	12 (7.5)	24 (14.9)	36 (22.4)	48 (29.8)	60 (37.3)	72 (44.7)	EVERY 12 MONTHS	EVERY 24 MONTHS
Coolant	I	I	I	I	I	I	I	I	R
Fork oil (5)					R				
Engine oil (3)	R	R	R	R	R	R	R	R	R
Final drive oil			R		R		R		
Headlight aiming		I	I	I	I	I	I		
Fork oil seals (1)		I	I	I		I	I		
Tyres - pressure / wear (2)	I	I	I	I	I	I	I	I	I
Transmission oil filler plug washer			R		R		R		
Nut/bolt tightness	I	I	I	I	I	I	I		
Suspensions and stability			I		I		I	I	I
Head cover fastening screws dampers	I	I	I	I	I	I	I		
Filter box drain plug		C	C	C	C	C	C	C	C
Brake lines		I	I	I	I	I	I		
Fuel pipes		I	I	I	I	I	I	I	I

- I : CHECK AND CLEAN, ADJUST, LUBRICATE OR REPLACE, IF NECESSARY
- C: CLEAN
- R: REPLACE
- A: ADJUST
- (1) Replace in case of leaks.

- (2) Check every month.
- (3) Check every 500 km (310 mi).
- (4) Check and clean, adjust or replace if necessary every 1,000 km (621 mi).
- (5): Replace at whichever of the following occurs first: 48,000 km (29.8 mi) or 4 years.

## Recommended products

**Piaggio Group recommends the use of products from its official partner Castrol for the scheduled maintenance of its vehicles.**

Only use lubricants and fluids which meet or exceed the performance characteristics specified. This also applies when topping up only.



## Table of recommended products

Product	Description	Specifications
Engine oil 10W -50	Synthetic-based lubricant for high performance four-stroke engines.	SAE 10W 50; API SL; JASO MA2
75W-140 lubricant for gearboxes and transmissions	Synthetic lubricant for gearboxes and transmissions	SAE 75W-140 - API GL5
Anti-freeze liquid, ready to use, colour red	Glycol ethylene based antifreeze liquid with organic additive technology corrosion inhibitor. Colour red, ready to use.	ASTM D 3306 - ASTM D 4656 - ASTM D 4985 - CUNA NC 956-16
Fork oil 7.5W	Fork oil.	SAE 7.5W
Molybdenum disulphide grease	Lithium grease with molybdenum disulphide.	Grey black grease
Petroleum jelly	neutral grease for battery terminals	-

Product	Description	Specifications
DOT 4 brake fluid	Synthetic brake fluid.	SAE J 1703; FMVSS 116; ISO 4925; CUNA NC 956 DOT4





The descriptions and images in this technical publication are given for illustrative purposes only. Piaggio & C. S.p.A. reserves the right to modify the components and parts of its products, without altering the essential commercial characteristics of the product itself as described and illustrated herein, at any time and as it deems necessary to improve its products or for any other manufacturing or commercial purposes, without being required to revise this publication in a timely manner. This publication may not include all versions and variants relating to each individual country.

The Moto Guzzi brand is owned by Piaggio & C. S.p.A.

© Copyright 2025 - Piaggio & C. S.p.A. All rights reserved. Reproduction of this publication in whole or in part is prohibited.  
Piaggio & C. S.p.A. Viale Rinaldo Piaggio, 25 - 56025 PONTEDERA (PI), Italy